

THE DEMOCRATIC SOCIALIST REPUBLIC OF SRI LANKA
MINISTRY OF AGRICULTURE, LIVESTOCK, LANDS AND IRRIGATION



PROJECT MANAGEMENT UNIT

Integrated Watershed & Water Resources Management Project

PROCUREMENT OF WORKS UNDER NATIONAL COMPETITIVE BIDDING

Bidding Documents

for

**Improvements to Sinnanai Anicut with gate arrangements in
Ampara District**

Contract No: LK-MOMDE-539131-CW-RFB

Issued: April 2026

<i>Bidder Number</i>	
<i>Name</i>	
<i>Address</i>	



INVITATION FOR BIDS

Integrated Watershed and Water Resources Management Project (IWWRMP)

Project No: P166865, Loan No: IDA-6619-LK

1. The Government of the Democratic Socialist Republic of Sri Lanka has applied for financing from the International Development Association (World Bank) towards the cost of **Integrated Watershed and Water Resources Management Project (IWRM Project)** and it intends to apply part of the proceeds of this credit to payment under the contracts mentioned in the schedule below.
2. Project Director of IWWRM Project, invites sealed bids from eligible and qualified bidders for the following **works** as given in the Table 01, on behalf of the Chairman, Project Procurement Committee of Integrated Watershed and Water Resources Management Project.

Table 01

No.	Contract No.	Description of Work	Experience / CIDA Registration	Bid Security and Validity Period	Non-Refundable Bidding Document Fee (Rs.)	Average annual volume of construction work & The minimum amount of liquid assets and/or credit facilities (Rs.)
1	LK-MOMDE-539131-CW-RFB	Improvements to Sinnanai Anicut with gate arrangements in Ampara District (Contract Period: 300days)	Grade: C6 or above Specialty: Irrigation & Drainage Canals	Bid security value: Rs. 362,276.00 Validity: Up to 24.09.2026	8,500.00	Rs. 38.00 Mn & Rs. 8.0 Mn

3. To be eligible for a contract award, the successful bidder shall not have been blacklisted and shall meet the requirements in the Bidding Document. Further the successful bidder shall have valid registration Grade in Construction Industry Development Authority (CIDA) as mentioned in above Table.
4. The Bidding documents may be available for inspection in the <https://www.iwrrmp.lk/web/procurement/section/procurement-notice> website for references.
5. Interested bidders may obtain further information from **Senior Project Specialist (Procurement & Contracts)**, IWWRM Project, 2nd Floor, Mahaweli Centre Building, No. 96, Ananda Coomaraswamy Mawatha, Colombo 07 and inspect the bidding documents at the same address given above during 9.00 a.m. to 3.00 p.m. from **17.04.2026 to 29.04.2026** (on working Days) by prior notification. (**Contact No: 0112691163**).
6. Prospective Bidders can obtain the Bidding Documents by a written request on a company/firm letter head, addressed to the Project Director, IWWRM Project, 2nd Floor, Mahaweli Centre Building, No. 96, Ananda Coomaraswamy Mawatha, Colombo 07. from **17.04.2026** up to **29.04.2026** from **9.30 hrs. to 15.00 hrs.** only on working days by **prior notification** (Contact No. 011-2691163), on payment of a non-refundable bid document fee as given above per set of Bidding Documents (Please refer Table: 01 for the amount) on Cash or sending the written request by email to iwrrmp@sltnet.lk with the scan copy of Bank Payment Slip paid the non-refundable bidding documents fee to the Integrated Watershed and Water Resources Management Project Bank Account no. of **7042633** at Bank of Ceylon, Hyde Park Branch.
7. The pre-bid meeting and site visit will be conducted as mentioned in table 02. Bidders are requested to inspect the sites with the assistance of the relevant officer.

Table 02

No.	Contract No.	Site visit	Pre-bid meeting	Bid Closing and Opening (Date & Time)
1	LK-MOMDE-539131-CW-RFB	Date: 21/04/2026 Time: 10.00 a.m. <u>Location:</u> Deputy Director's office, Ampara Range, Provincial Irrigation Department, Yard Road, Kalmunai.	Date: 22/04/2026 Time: 2.00 p.m. Conference Room, IWWRMP 2 nd Floor, Mahaweli Centre Building, No. 96, Ananda Coomaraswamy Mawatha, Colombo 07.	Date: 30/04/2026 Time: 2.00 p.m.

8. All pages of the Bidding Documents shall be signed by the bidder and affixed to his seal.
9. Completed Sealed Bid with **duplicate**, clearly marked the contract name and the number on the top left corner of the envelope may be dispatched either by Registered Post or hand delivered or courier to the **Project Director, IWWRM Project, 2nd Floor, Mahaweli Centre Building, No. 96, Ananda Coomaraswamy Mawatha, Colombo 07** as specified in the **Table 02**. Bids will be opened immediately thereafter. Bidders or their authorized representatives, not exceeding two (2) in numbers, are permitted to be present at the opening of bids.

**Project Director,
Integrated Watershed and Water Resources Management Project
2nd Floor, Mahaweli Centre Building,
No.96, Ananda Coomaraswamy Mawatha,
Colombo 07.
16.04.2025**

Table of Contents

Section I. Instructions to Bidders (ITB).....	1 -1
Section II. Bidding Data Sheet (BDS).....	2-1
Section III. Conditions of contracts	3-1
Section IV. Contract data.....	4-1
Section V. Standard forms (Contract).....	5-1
Section VI. Specifications.....	6-1
Section VII. Form of BID	7-1
Section VIII. BOQ	8-1
Section IX. Schedules	9-1
Section X. Drawings	10-1
Section XI Standard forms (BID)	11-1

Section - 1

Instructions to Bidders (ITB)

Note: Bidders are advised to refer Section 1 – Instructions to Bidders of Standard Bidding Document ICTAD Publication No. – ICTAD/SBD/02 – Second Edition-January 2007

Section - 2

Bidding Data

Reference Only

Section 2 - Bidding Data

Instructions to Bidders Clause Reference	Entry
1.1	<p>Employer’s Name and Address Name: <i>Project Director,</i> <i>Integrated Watershed & Water Resources Management Project</i> Address: <i>2ndFloor, No.96, Ananda Coomaraswamy Mawatha, Colombo 07.</i></p>
1.1	<p>Scope of Works <i>Improvements to Sinnanai Anicut with gate arrangements in Ampara District</i> which including i. Improvement to the Sinnai anicut by providing concrete covering and providing additional opening ii. Fabrication, supplying and fixing of Gates <i>Located at Sagamam Tank and downstream area in Ampara District</i></p>
1.2	<p>Time for Completion The Time for Completion for the whole of works shall be 300 Calendar Days</p>
2.1	<p>Source of funds The source of funds is <i>International Development Association (IDA) – World Bank</i></p>
3	<p>Substitute by the following:</p> <p>3.1 The World Bank requires that the Government of Sri Lanka (including beneficiaries of World Bank financing); bidders (applicants/proposers), consultants, contractors and suppliers; any sub-contractors, sub-consultants, service providers or suppliers; any agents (whether declared or not); and any of their personnel, observe the highest standard of ethics during the procurement process, selection and contract execution of World Bank-financed contracts, and refrain from Fraud and Corruption.</p> <p>3.2 The World Bank requires compliance with its policy in regard to corrupt and fraudulent practices as set forth below.</p> <p>3.3 In pursuance to this policy, The World Bank:</p> <p>a. Defines, for the purposes of this provision, the terms set forth below as follows:</p> <p>i. “corrupt practice” is the offering, giving, receiving, or soliciting, directly or indirectly, of anything of value to influence improperly the actions of another party;</p> <p>ii. “fraudulent practice” is any act or omission, including misrepresentation, that knowingly or recklessly misleads, or attempts to mislead, a party to obtain financial or other benefit or to avoid an obligation;</p> <p>iii. “collusive practice” is an arrangement between two or more parties designed to achieve an improper purpose, including to influence improperly the actions of another party;</p> <p>iv. “coercive practice” is impairing or harming, or threatening to impair or harm, directly or indirectly, any party or the property of the party to influence improperly the actions of a party;</p> <p>v. “obstructive practice” is:</p>

	<p>a. deliberately destroying, falsifying, altering, or concealing of evidence material to the investigation or making false statements to investigators in order to materially impede a World Bank investigation into allegations of a corrupt, fraudulent, coercive, or collusive practice; and/or threatening, harassing, or intimidating any party to prevent it from disclosing its knowledge of matters relevant to the investigation or from pursuing the investigation; or</p> <p>b. acts intended to materially impede the exercise of the World Bank’s inspection and audit rights provided for under paragraph 3.4 below.</p> <p>b. rejects a proposal for award if the World Bank determines that the firm or individual recommended for award, any of its personnel, or its agents, or its subconsultants, sub-contractors, service providers, suppliers and/ or their employees, has, directly or indirectly, engaged in corrupt, fraudulent, collusive, coercive, or obstructive practices in competing for the contract in question;</p> <p>c. In addition to the legal remedies set out in the relevant Legal Agreement, may take other appropriate actions, including declaring mis-procurement, if the World Bank determines at any time that representatives of the Government of Sri Lanka or of a recipient of any part of the proceeds of the loan engaged in corrupt, fraudulent, collusive, coercive, or obstructive practices during the procurement process, selection and/or execution of the contract in question, without taking timely and appropriate action satisfactory to the World Bank to address such practices when they occur, including by failing to inform the World Bank in a timely manner at the time they knew of the practices;</p> <p>d. Sanctions, pursuant to the World Bank’s Anti-Corruption Guidelines and in accordance with its prevailing sanctions policies and procedures as set forth in the WBG’s Sanctions Framework any firm or individual – determined at any time by the World Bank to have engaged in Fraud and Corruption in connection with the procurement process, selection and/or execution of a World Bank-financed contract;</p> <p>e. Requires that, for World Bank-financed operations to be implemented utilizing national procurement arrangements, as well as PPPs, agreed by the World Bank, bidders (applicants/proposers) and consultants submitting bids/proposals will be required to accept the application of, and agree to comply with, the Anti-Corruption Guidelines during the procurement process, selection and/or contract execution, including the World Bank’s right to sanction as set forth in paragraph 2.2 d., and the World Bank’s inspection and audit rights as set forth in paragraph 3.4. The Employer shall consult and apply the World Bank Group’s lists of firms and individuals suspended or debarred. In the event the Employer signs a contract with a firm or an individual suspended or debarred by the World Bank Group, the World Bank does not finance the related expenditures and may apply other remedies as appropriate; and</p> <p>g. Requires that, when a United Nations (UN) agency is selected to provide goods, works, non-consulting services and technical assistance, the above provisions regarding sanctions on Fraud and Corruption shall apply in their entirety to all contractors, consultants, sub-contractors, sub-consultants, service providers, suppliers, and their employees, that signed contracts with the UN agency.</p> <p>3.4 In further pursuance of this policy, Bidders shall permit and shall cause its agents (whether declared or not), sub-contractors, sub-consultants, service providers, or suppliers and any personnel thereof, to permit the World Bank to inspect all accounts, records and other documents relating to any prequalification process, bid submission, and contract performance (in the case of award), and to have them audited by auditors appointed by the World Bank.</p>
--	--

<p>4.1</p>	<p>Qualification Information The following information shall be provided in Section 9 - Schedules:</p> <ul style="list-style-type: none"> • ICTAD registration <ul style="list-style-type: none"> Registration number Grade Specialty Expiry date • VAT registration number • Attach construction program • Attach legal status (Sole proprietor, Partnership, Company etc.) • Attach authentication for signatory • Total monetary value of construction work performed for each of the last five years • Experience in works of a similar nature and size for each of the last ten years • Construction equipment • Staffing • Attach Work plan and methods; 																																				
<p>4.2 (a)</p>	<p>CIDA registration required The registration required; Specialty: <i>Irrigation and Drainage Canals</i> Grade: <i>C 6 or above</i></p>																																				
<p>4.2 (b)</p>	<p>Average annual volume of construction work performed in last 10 years Average annual volume of construction work performed in last ten years shall be at least Rs. 38.0 million</p>																																				
<p>4.2 (c)</p>	<p>Experience in works of a similar nature and site for each of the last ten years shall be at least Rs. 14.0 Million (Excluding VAT)</p>																																				
<p>4.2 (d)</p>	<p>Essential equipment Proposals for the timely acquisition (own, lease, hire, etc.) of the following essential equipment shall be;</p> <table border="1" data-bbox="440 1339 1417 2002"> <thead> <tr> <th data-bbox="440 1339 520 1420">No.</th> <th data-bbox="520 1339 1206 1420">Equipment Type and Characteristics</th> <th data-bbox="1206 1339 1417 1420">Min. Number Required</th> </tr> </thead> <tbody> <tr> <td data-bbox="440 1420 520 1473">1</td> <td data-bbox="520 1420 1206 1473">Crawler excavator - 120 HP, Bucket capacity 1.0 m³</td> <td data-bbox="1206 1420 1417 1473">1</td> </tr> <tr> <td data-bbox="440 1473 520 1527">2</td> <td data-bbox="520 1473 1206 1527">Loader backhoe</td> <td data-bbox="1206 1473 1417 1527">1</td> </tr> <tr> <td data-bbox="440 1527 520 1581">3</td> <td data-bbox="520 1527 1206 1581">Concrete mixers 1 m³</td> <td data-bbox="1206 1527 1417 1581">3</td> </tr> <tr> <td data-bbox="440 1581 520 1635">4</td> <td data-bbox="520 1581 1206 1635">Tractor with trailers</td> <td data-bbox="1206 1581 1417 1635">3</td> </tr> <tr> <td data-bbox="440 1635 520 1688">5</td> <td data-bbox="520 1635 1206 1688">Porker vibrators</td> <td data-bbox="1206 1635 1417 1688">2</td> </tr> <tr> <td data-bbox="440 1688 520 1742">6</td> <td data-bbox="520 1688 1206 1742">Transport equipment / Tipper</td> <td data-bbox="1206 1688 1417 1742">3</td> </tr> <tr> <td data-bbox="440 1742 520 1796">7</td> <td data-bbox="520 1742 1206 1796">Water Bowser with sprinkler 5000 L Capacity</td> <td data-bbox="1206 1742 1417 1796">2</td> </tr> <tr> <td data-bbox="440 1796 520 1850">8</td> <td data-bbox="520 1796 1206 1850">Mobile Generator</td> <td data-bbox="1206 1796 1417 1850">1</td> </tr> <tr> <td data-bbox="440 1850 520 1904">9</td> <td data-bbox="520 1850 1206 1904">Plate Compactor</td> <td data-bbox="1206 1850 1417 1904">1</td> </tr> <tr> <td data-bbox="440 1904 520 1957">10</td> <td data-bbox="520 1904 1206 1957">Rammer</td> <td data-bbox="1206 1904 1417 1957">1</td> </tr> <tr> <td data-bbox="440 1957 520 2002">11</td> <td data-bbox="520 1957 1206 2002">Vibrating Sheep foot roller not less than 10 Ton</td> <td data-bbox="1206 1957 1417 2002">1</td> </tr> </tbody> </table>	No.	Equipment Type and Characteristics	Min. Number Required	1	Crawler excavator - 120 HP, Bucket capacity 1.0 m ³	1	2	Loader backhoe	1	3	Concrete mixers 1 m ³	3	4	Tractor with trailers	3	5	Porker vibrators	2	6	Transport equipment / Tipper	3	7	Water Bowser with sprinkler 5000 L Capacity	2	8	Mobile Generator	1	9	Plate Compactor	1	10	Rammer	1	11	Vibrating Sheep foot roller not less than 10 Ton	1
No.	Equipment Type and Characteristics	Min. Number Required																																			
1	Crawler excavator - 120 HP, Bucket capacity 1.0 m ³	1																																			
2	Loader backhoe	1																																			
3	Concrete mixers 1 m ³	3																																			
4	Tractor with trailers	3																																			
5	Porker vibrators	2																																			
6	Transport equipment / Tipper	3																																			
7	Water Bowser with sprinkler 5000 L Capacity	2																																			
8	Mobile Generator	1																																			
9	Plate Compactor	1																																			
10	Rammer	1																																			
11	Vibrating Sheep foot roller not less than 10 Ton	1																																			

4.2 (e)	<p>Qualifications and experience of the Contract Manager and other Key personnel</p> <table border="1" data-bbox="416 248 1430 1039"> <thead> <tr> <th data-bbox="416 248 676 383">Key personnel</th> <th data-bbox="676 248 948 383">Qualifications</th> <th data-bbox="948 248 1078 383">No. of Position</th> <th data-bbox="1078 248 1249 383">Experience</th> <th data-bbox="1249 248 1430 383">Similar work Experience</th> </tr> </thead> <tbody> <tr> <td data-bbox="416 383 676 517">1. Contract Manager</td> <td data-bbox="676 383 948 517">Engineering Degree or equivalent qualification in Relevant field</td> <td data-bbox="948 383 1078 517">1</td> <td data-bbox="1078 383 1249 517">07 yrs</td> <td data-bbox="1249 383 1430 517">03 yrs</td> </tr> <tr> <td data-bbox="416 517 676 618">2. Site Engineer</td> <td data-bbox="676 517 948 618">B.Sc. (Civil Engineering) degree or equivalent</td> <td data-bbox="948 517 1078 618">1</td> <td data-bbox="1078 517 1249 618">05yrs</td> <td data-bbox="1249 517 1430 618">03yrs</td> </tr> <tr> <td data-bbox="416 618 676 752">3.Environmental and Social officer</td> <td data-bbox="676 618 948 752">Degree or equivalent qualification in Relevant field</td> <td data-bbox="948 618 1078 752">1</td> <td data-bbox="1078 618 1249 752">01 yrs</td> <td data-bbox="1249 618 1430 752">-</td> </tr> <tr> <td data-bbox="416 752 676 887">4.Health and Safety officer</td> <td data-bbox="676 752 948 887">Degree or equivalent qualification in Relevant field</td> <td data-bbox="948 752 1078 887">1</td> <td data-bbox="1078 752 1249 887">01 yrs</td> <td data-bbox="1249 752 1430 887">-</td> </tr> <tr> <td data-bbox="416 887 676 954">5.Engineering Assistant (Civil)</td> <td data-bbox="676 887 948 954">NDT or equivalent</td> <td data-bbox="948 887 1078 954">1</td> <td data-bbox="1078 887 1249 954">03 yrs</td> <td data-bbox="1249 887 1430 954">01 yrs</td> </tr> <tr> <td data-bbox="416 954 676 1039">6. Work Supervisor (Civil)</td> <td data-bbox="676 954 948 1039">NCT</td> <td data-bbox="948 954 1078 1039">2</td> <td data-bbox="1078 954 1249 1039">03 yrs</td> <td data-bbox="1249 954 1430 1039">01 yrs</td> </tr> </tbody> </table> <p data-bbox="416 1066 1441 1178">The Bidder must demonstrate that it will have suitably qualified Contract Manager and suitably qualified other key personnel in adequate numbers, as described in the table above.</p>	Key personnel	Qualifications	No. of Position	Experience	Similar work Experience	1. Contract Manager	Engineering Degree or equivalent qualification in Relevant field	1	07 yrs	03 yrs	2. Site Engineer	B.Sc. (Civil Engineering) degree or equivalent	1	05yrs	03yrs	3.Environmental and Social officer	Degree or equivalent qualification in Relevant field	1	01 yrs	-	4.Health and Safety officer	Degree or equivalent qualification in Relevant field	1	01 yrs	-	5.Engineering Assistant (Civil)	NDT or equivalent	1	03 yrs	01 yrs	6. Work Supervisor (Civil)	NCT	2	03 yrs	01 yrs
Key personnel	Qualifications	No. of Position	Experience	Similar work Experience																																
1. Contract Manager	Engineering Degree or equivalent qualification in Relevant field	1	07 yrs	03 yrs																																
2. Site Engineer	B.Sc. (Civil Engineering) degree or equivalent	1	05yrs	03yrs																																
3.Environmental and Social officer	Degree or equivalent qualification in Relevant field	1	01 yrs	-																																
4.Health and Safety officer	Degree or equivalent qualification in Relevant field	1	01 yrs	-																																
5.Engineering Assistant (Civil)	NDT or equivalent	1	03 yrs	01 yrs																																
6. Work Supervisor (Civil)	NCT	2	03 yrs	01 yrs																																
4.2 (f)	<p>Liquid assets and/or credit facilities required The minimum amount of liquid assets and/or credit facilities, net of other contractual commitments and exclusive of any advance payments which may be made under the Contract, shall be not less than Rs. 8.0 million</p>																																			
8.3	<p>The employer may conduct a site visit concurrently with the pre-bid meeting referred to in Clause 19. The site visit will be conduct as follow. Date & Time : 21st April 2026 at 10.00 a.m Commencing Venue : Office of the Deputy Director of Irrigation, Ampara Range, Kalmunai</p>																																			
10.1	<p>Clarification of Bidding Documents Employer's address for clarification of bidding documents is:</p> <p>Name of Officer: Project Director, IWWRMP Address: 2nd Floor, Mahaweli Centre Building, No. 96, Ananda Coomaraswamy Mawatha, Colombo 07. Phone: 0112691163 Facsimile: 0112691163 E-mail: iwwrmp@sltnet.lk</p>																																			

13.1(A) (j)
13.1(B) (d)

The Bidder shall submit the following additional documents in its Bid:

Note: list any additional document not already listed in ITB 13.1 that must be submitted with the Bid. The list of additional documents should include the following:]

Code of Conduct (ESHS)

The Bidder shall submit its Code of Conduct that will apply to Contractor's Personnel (as defined in Sub-clause 1.1.2.7 of the GC), to ensure compliance with its Environmental, Social, Health and Safety (ESHS) obligations under the contract. *[Note: Complete and include the risks to be addressed by the Code in accordance with Schedule 10, e.g. risks associated with: labor influx, spread of communicable diseases, sexual harassment, gender-based violence, sexual exploitation and abuse, illicit behavior and crime, and maintaining a safe environment etc.]*

In addition, the Bidder shall detail how this Code of Conduct will be implemented. This will include: how it will be introduced into conditions of employment/engagement, what training will be provided, how it will be monitored and how the Contractor proposes to deal with any breaches.

The Contractor shall be required to implement the agreed Code of Conduct.

Management Strategies and Implementation Plans (MSIP) to manage the (ESHS) risks

The Bidder shall submit Management Strategies and Implementation Plans (MSIP) to manage the following key Environmental, Social, Health and Safety (ESHS) risks.

[Note: insert name of plan and specific risk/s];

- *[e.g. Traffic Management Plan to ensure safety of local communities from construction traffic];*
- *[e.g. Water Resource Protection Plan to prevent contamination of drinking water];*
- *[e.g. Boundary Marking and Protection Strategy for mobilization and construction to prevent offsite adverse impacts];*
- *[e.g. Strategy for obtaining Consents/Permits prior to the start of relevant works such as opening a quarry or borrow pit];*
- *[e.g. Gender based violence and sexual exploitation and abuse (GBV/SEA) prevention and response action plan].*

The Contractor shall be required to submit for approval, and subsequently implement, the Contractor's Environment and Social Management Plan (C-ESMP), in accordance with the Particular Conditions of Contract Sub-Clause 4.1, that includes the agreed Management Strategies and Implementation Plans described here.

[Note: The extent and scope of these requirements should reflect the significant ESHS risks or requirements set out in Schedule 10 as advised by Environmental/Social specialist/s. The key risks to be addressed by the Bidder should be identified by Environmental/Social specialist/s, for example, from the Environmental and Social Impact Assessment (ESIA), Environmental and Social Management Plan (ESMP), Resettlement Action Plan (RAP), and/or Consent Conditions (regulatory authority conditions attached to any permits or approvals for the project), up to a maximum of four. The risks may arise during mobilization or construction phases, and may include construction traffic impacts on the community, pollution of drinking water, depositing on

	<i>private land and impacts on rare species etc. The management strategies and/or implementation plans to address these could include, as appropriate: mobilization strategy, strategy for obtaining consents/permits, traffic management plan, water resource protection plan, bio-diversity protection plan and a strategy for marking and respecting work site boundaries etc.]</i>
14.4	Adjustments for change in cost The Contract is subjected to price adjustment
15.1	Currency of Bid Rates and prices shall be quoted by the bidders entirely in <i>Sri Lankan rupees</i> .
16.1	Period of Bid validity: The Bid shall be valid up to 119 days from the bid submission deadline date (27th August 2026).
17.1	Amount of Bid security: The amount of Bid Security is Sri Lankan rupees: Three hundred sixty-two thousand two hundred seventy-six Sri Lankan rupees (LKR 362,276.00) The Bid security shall, be in the form of an unconditional bank guarantee issued from a reputed bank recognized by the Central Bank of Sri Lanka bank located in Sri Lanka. The format of the bid security should be in accordance with the specimen form of bid security included in the bidding document (Section 11).
17.2	Validity of Bid Security The Bid Security shall be valid up to 147 days from the date of closing of the bids (excluding closing date).(24th September 2026.)
17.5	The bid security of the successful bidder will be returned when the bidder has signed the Agreement and furnished the required Performance Securities including the Environmental, Social, Health and Safety (ESHS) Performance Security pursuant to ITB 35.1.
17.6 (c) (ii)	Furnish the required Performance Securities including the Environmental, Social, Health and Safety (ESHS) Performance Security pursuant to ITB 35.1.
19.1	Pre-Bid meeting Venue, time, and date of the pre-bid meeting. Date: 22 th April 2026 Time: 02:00 pm Venue: Conference Room, IWWRMP 2 nd Floor, Mahaweli Centre Building, No. 96, Ananda Coomaraswamy Mawatha, Colombo 07.
21.2 (a)	Employer's Address for the purpose of bid submission is: <i>Project Director</i> <i>Integrated Watershed & Water Resources Management Project</i> <i>2nd Floor, Mahaweli Centre Building,</i> <i>No.96, Ananda Coomaraswamy Mawatha,</i> <i>Colombo 07.</i>

21.2 (b)	<p>Identification number of Contract Identification Number of the Contract is:</p> <p>LK-MOMDE-539131-CW-RFB</p>
22.1	<p>Deadline for submission of Bids Deadline for submission of Bids: 30th April 2026 Time: 02:00 pm</p>
25.1	<p>Bid opening Venue, time, and date of bid opening. Time: 02:00 pm Date: 30th April 2026 Venue: Conference Room, IWWRMP 2nd Floor, Mahaweli Centre Building, No. 96, Ananda Coomaraswamy Mawatha, Colombo 07.</p>
31.1	<p>Preference for Domestic Bidders – Not Applicable</p>
35.1	<p>Amount of Performance Security</p> <p>The Standard Form of Performance Security acceptable to the Employer shall be a Guarantee from an Agency accepted and stated in the Procurement Guidelines.</p> <p>The amount of the Performance Security is 7% of the Initial Contract Price.</p> <p>The Performance Security shall be valid until 28 Days beyond the Time for Completion (<i>date</i>).</p> <p>In addition, the successful Bidder <i>shall</i> submit an Environmental, Social, Health and Safety (ESHS) Performance Security within 14 Days of receipt of the Letter of Acceptance.</p> <p>The amount of the Environmental, Social, Health and Safety (ESHS) Performance Security is 3% of the initial Contract Price.</p> <p>The Environmental, Social, Health and Safety (ESHS) Performance Security shall be valid until 28 days beyond the defects liability period (<i>date</i>).</p> <p>Bid security shall only be an unconditional guarantee issued by a bank recognized by the Central Bank of Sri Lanka or Construction Guarantee Fund (CGF) in accordance with the format given.</p> <p>Additionally Performance Guarantees will be added up to 10% on the situation where the evaluated price having considerable gap, which would be decided by PE.</p>
37	<p>Fees and types of reimbursable expenses to be paid to the Adjudicator shall be on a case to case basis and shall be shared equally by the Contractor and the Employer.</p>

Section - 3

Conditions of Contract

Note:

Bidders are advised to refer Section 3 – Condition of Contract of Standard Bidding Document ICTAD Publication No. – ICTAD/SBD/02 –second

Section - 4

Contract Data

Reference Only

Section 4 – Contract Data

Conditions of Contract Clause Number/s		
(* 1.1.2.2 & 1.3	Employer's name and address	Name: Project Director, Integrated Watershed & Water Resources Management Project Address: 2 nd Floor, Mahaweli Centre Building, No.96, Ananda Coomaraswamy Mawatha, Colombo 07.
1.3	Contractor's name and address	Name: Address:
(* 1.1.2.4 & 1.3	Engineer's name and address	Name: Deputy Director of Irrigation, Ampara Range Address: Deputy Director's office, Ampara Range, Provincial Irrigation Department, Yard Road, Kalmunai
	Engineer's Representative name and address	Name: Divisional Irrigation Engineer, Thambiluvil Division. Address: Divisional Irrigation Engineer's Office, Thambiluvil Division, Pottuvil Road, Thambiluvil
1.1.2.5 Contractor's Personnel	Key Personnel The following is added at the end of the sub-clause: "Contractor's Personnel includes Key Personnel as named in the Contract."	
1.1.2.9	Replace existing Clause 1.1.2.9 with following: "Dispute Adjudication Board" (DAB) means three persons appointed under Sub-Clause 19.2 [Appointment of the Dispute Adjudication Board] or Sub-Clause 19.3 [Failure to Agree on the Composition of the Dispute Adjudication Board] of the Conditions of Contract.	
(* 1.1. 3.3	Time for Completion of the Works	Time for Completion is 300 <i>calendar Days from the commencement date.</i>
(* 1.1.3.7	Defects Notification Period	Defects Notification Period is 365 Days
1.1.6.8	The following is added after Sub-Clause 1.1.6.7 "ESHS" means environmental, social (including sexual exploitation and abuse (SEA) and gender-based violence (GBV)), health and safety.	
(* 2. 1	Right to access to the Site	14 Days after Letter of Acceptance

(*) 3.1	Engineer's Duties and Authority	<p>The Engineer shall obtain the specific approval of the Employer before taking action under the following Sub-Clauses of these Conditions:</p> <p>a) Clause 13, where the final effect of the Variations aggregate exceed 5% of the Contract Price</p>
<p>4.1 Contractor's General Obligations</p>	<p>Insert in the fifth paragraph after the words "<i>The Contractor shall, whenever required by the Engineer, submit details of the arrangements and methods which the Contractor proposes to adopt for the execution of the Works.</i>"</p> <p>"Notwithstanding Sub-Clause 8.1, the Contractor shall not carry out any Works, including mobilization and/or pre-construction activities (e.g. limited clearance for haul roads, site accesses and work site establishment, geotechnical investigations or investigations to select ancillary features such as quarries and borrow pits), unless the Engineer is satisfied that appropriate measures are in place to address environmental, social, health and safety risks and impacts. At a minimum, the Contractor shall apply the Management Strategies and Implementation Plans and Code of Conduct, submitted as part of the Bid and agreed as part of the Contract. The Contractor shall submit, on a continuing basis, for the Engineer's prior approval, such supplementary Management Strategies and Implementation Plans as are necessary to manage the ESHS risks and impacts of ongoing works. These Management Strategies and Implementation Plans collectively comprise the Contractor's Environmental and Social Management Plan (C-ESMP). The C-ESMP shall be approved prior to the commencement of construction activities (e.g. excavation, earth works, bridge and structure works, stream and road diversions, quarrying or extraction of materials, concrete batching and asphalt manufacture). The approved C-ESMP shall be reviewed, periodically (but not less than every six (6) months), and updated in a timely manner, as required, by the Contractor to ensure that it contains measures appropriate to the Works activities to be undertaken. The updated C-ESMP shall be subject to prior approval by the Engineer.</p>	
(*) 4.2	Amount of Performance Security	<p>7 % of the Initial Contract Price, in the currencies and proportions in which the Contract Price is payable. The acceptable form is Unconditional Guarantee.</p> <p>Performance Security shall only be an unconditional guarantee issued by a bank recognized by the Central Bank of Sri Lanka in accordance with the format given</p> <p>3 % of the Initial Contract Price</p> <p>The ESHS Performance Security will be in the form of a "<i>demand guarantee</i>" in the amount(s) of 3% percent of the Accepted Contract Amount and in the same currency (ies) of the Accepted Contract Amount.</p>

<p>4.2 Performance Security</p>	<p>Add the following</p> <p>The Contractor shall obtain (at his cost) an Environmental, Social, Safety and Health (ESHS) Performance Security for compliance with the Contractor’s ESHS obligations, for 3% of Initial Contract Price.</p> <p>The Contractor shall deliver ESHS Performance Security to the Employer within 14 days after receiving the Letter of Acceptance, and shall send a copy to the Engineer. The ESHS Performance Security shall be issued by a reputable bank selected by the Contractor, and shall be in the form annexed to the Particular Conditions, as stipulated by the Employer in the Contract Data, or in another form approved by the Employer.</p> <p>The Contractor shall ensure that the ESHS Performance Security is valid and enforceable until the Contractor has executed and completed the Works and remedied any defects. If the terms of the ESHS Performance Security specify its expiry date, and the Contractor has not become entitled to receive the Performance Certificate (which, if applicable, includes satisfactory performance of the ESHS obligations), by the date 28 days prior to the expiry date, the Contractor shall extend the validity of the ESHS Performance Security until the Works have been completed and any defects have been remedied.</p> <p>The Employer shall return the ESHS Performance Security to the Contractor within 21 days after receiving a copy of the Performance Certificate.</p>
--	--

<p>4.14 Progress Reports</p>	<p>Sub-Clause 4.21 (g) is replaced by the following:</p> <p>“4.14 (g) the Environmental, Social, Health and Safety (ESHS) metrics set out in Appendix B”</p> <p>At the end of, and as part of Sub-Clause 4.14 add a new paragraph as follows:</p> <p>“The Contractor shall provide immediate notification to the Engineer of incidents in the following categories. Full details of such incidents shall be provided to the Engineer within the timeframe agreed with the Engineer.</p> <ul style="list-style-type: none">(a) confirmed or likely violation of any law or international agreement;(b) any fatality or serious (lost time) injury;(c) significant adverse effects or damage to private property (e.g. vehicle accident, damage from fly rock, working beyond the boundary)(d) major pollution of drinking water aquifer or damage or destruction of rare or endangered habitat (including protected areas) or species; or <p>any allegation of gender-based violence (GBV), sexual exploitation or abuse, sexual harassment or sexual misbehavior, rape, sexual assault, child abuse, or defilement, or other violations involving children.</p>
---	--

6.8 Contractor's Personnel	Key Personnel				
	Key personnel	Qualifications	No. of Position	Experience	Similar work Experience
	1. Contract manager	Engineering Degree or equivalent qualification in Relevant field	1	07 yrs	03 yrs
	2. Site Engineer	B.Sc. (Civil Engineering) degree or equivalent	1	05yrs	03yrs
	3.Environmental and Social officer	Degree or equivalent qualification in Relevant field	1	01 yrs	-
	4.Health and Safety officer	Degree or equivalent qualification in Relevant field	1	01 yrs	-
	5.Engineering Assistant (Civil)	NDT or equivalent	1	03 yrs	01 yrs
6. Work Supervisor (Civil)	NCT	2	03 yrs	01 yrs	

Sub-Clauses 6.8 (d) is amended by inserting “or” at the end:

“6.9 (d).....; or”

Sub-Clauses 6.8 (e) is inserted as follows:

“6.9 (e) undertakes behavior which breaches the Code of Conduct (ESHS) (e.g. spreading communicable diseases, sexual harassment, gender-based violence, (GBV), sexual exploitation or abuse, illicit activity or crime).”

After the sentence: *“If appropriate, the Contractor shall then appoint (or cause to be appointed) a suitable replacement person.”* the following is added as a new paragraph:

“The Contractor’s Personnel includes Key Personnel. If the Contractor intends to replace a Key Personnel, the Contractor shall, not less than 30 days before the intended date of replacement, give notice to the Engineer, the name, address, academic qualifications and relevant experience of the intended replacement Key Personnel. The Contractor shall not, without the prior consent of the Engineer, revoke the appointment of the Key Personnel or appoint a replacement.”

(*) 8.7	Liquidated damages for the Works	0.05 % of the Initial Contract Price per Day
(*) 8.7	Maximum amount of liquidated damages	5% of the Initial Contract Price
12.2 (b)	Method of Measurement	The Method of Measurement shall be SLS 573.
13.3 Variation procedure	Sub-Clause 13.3. (a) is replaced with the following: “(a) a description of the proposed work to be performed, a programme for its execution and sufficient ESHS information to enable an evaluation of ESHS risks and impacts;”	
(*) 13.4(b)	Percentage for adjustment of Provisional Sums	10 %
(*) 13.4(b) II	Overhead and profit factor percentage	17%
13.7 Adjustment for changes in Cost	Last paragraph “The weightings for each of the inputs of cost” shall be substituted by the following: “The weightings for each of the inputs of cost given in this Clause shall be adjusted only if they have been rendered unreasonable, unbalanced or inapplicable, as a result of Variations.”	

13.7	Weightings of Inputs	Indices No Input Name Input Percentage		
		M7	Metal	19.00%
		M3	Cement	17.00%
		M13	Reinforcement Steel	14.00 %
		M8	Sand	12.00%
		L1	Skilled Labour	10.00%
		L3	Unskilled Labour	8.00%
		P1	Small Equipment	5.00%
		P3	Fuel	5.00%
		Total		
<p>Non-adjustable element shall be:</p> <ul style="list-style-type: none"> • All Preliminary Items <p>All provisional sum & Lump sum Items</p>				

(*) 14.2	Total Advance Payment	40 % of the Initial Contract Price excluding provisional sums and contingencies
(*) 14.3(c)	Percentage of retention	10 %
(*) 14.3(c)	Limit of Retention Money	5 % of the Initial Contract Price
14.5	Minimum amount of Interim Payment Certificates.	10% of the Initial Contract Price
(*) 14.5 Issue of Interim Payment Certificate	<p>The following is added to the third paragraph as (c):</p> <p>i. if the Contractor was, or is, failing to perform any ESHS obligations or work under the Contract, the value of this work or obligation, as determined by the Engineer, may be withheld until the work or obligation has been performed, and/or the cost of rectification or replacement, as determined by the Engineer, may be withheld until rectification or replacement has been completed. Failure to perform includes, but is not limited to the following:</p> <p>a) failure to comply with any ESHS obligations or work described in the Works' Requirements which may include: working outside site boundaries, excessive dust, failure to keep public roads in a safe usable condition, damage to offsite vegetation, pollution of water courses from oils or sedimentation, contamination of land e.g. from oils, human waste, damage to archeology or cultural heritage features, air pollution as a result of unauthorized and/or inefficient combustion;</p> <p>b) failure to regularly review C-ESMP and/or update it in a timely manner to address emerging ESHS issues, or anticipated risks or impacts;</p> <p>c) failure to implement the C-ESMP e.g. failure to provide required training or sensitization;</p> <p>d) failing to have appropriate consents/permits prior to undertaking Works or related activities;</p> <p>e) failure to submit ESHS report/s (as described in Appendix B), or failure to submit such reports in a timely manner;</p> <p>f) Failure to implement remediation as instructed by the Engineer within the specified timeframe (e.g. remediation addressing non-compliance/s).</p>	
(*)14.8	Alternative method for Payment of Retention	On reaching the limit of retention, stated in the Contract Data under Sub-Clause 14.3, the Contractor may substitute full retention money with an unconditional guarantee acceptable to the Employer to a value equal to the full retention money, and valid up to 28 Days beyond the end of Defect Notification Period. On receipt of such guarantee the Employer shall repay the full retention money. The guarantee will be released to the Contractor upon the certification of the Engineer that all Defects notified by the Engineer to the Contractor before the end of this period have been corrected.

(*) 18.2	Third Party Insurance	This Amount of insurance per occurrence is:		
			Minimum Insurance Amount	Maximum Deductible
		(a) for the works, Plant and materials:	110% of the contract Price	Rs 50,000/-
		(b) For loss or damage to equipment	Replacement value of the Equipment	Rs 50,000/-
		(c) for losses or damage to property (except the works, plant, Materials, and Equipment) in connection with Contract	Rs 1.0 million	Rs 50,000/-
		(d) for personal injury or death: (i) of the Contractor's employees per event	Rs 1,000,000 per employee	No Deductible
		(ii) of other people per event	Rs 1,000,000 per person	No Deductible
		<p><i>Clause 19.0 Claims, Disputes and Arbitration</i> Delete existing sub-clause 19.2 (<i>Dispute Resolution</i>), Delete existing sub-clause 19.3 (<i>Procedure for Adjudication</i>), Delete existing sub-clause 19.4 (<i>Replacement of Adjudicator</i>), Delete existing sub-clause 19.5 (<i>Arbitration</i>), and insert the following new sub-clauses;</p> <p>19.2 <i>Appointment of the Dispute Adjudication Board</i> 19.3 <i>Failure to Agree on the Composition of the Dispute Adjudication Board</i> 19.4 <i>Obtaining Dispute Adjudication Board's Decision</i> 19.5 <i>Failure to Comply with Dispute Adjudication Board's Decision</i> 19.6 <i>Expiry of Dispute Adjudication Board's Appointment</i> 19.7 <i>Arbitration</i></p>		

<p>19.2</p>	<p>Appointment of the Dispute Adjudication Board</p>	<p>Any dispute of whatever nature arising out of or in relation to this agreement shall in the first instance be referred to a Dispute Adjudication Board (DAB) for decision in accordance with Sub-Clause 19.4 [Obtaining Dispute Adjudication Board’s Decision]. The Parties shall appoint a DAB within 28 Days from the Commencement Date.</p> <p>The DAB shall comprise, three suitably qualified persons (“the members”), who shall be professionals experienced in the type of construction involved in the Works and with the interpretation of contractual documents, one of whom shall serve as chairman.</p> <p>Within 28 Days from the Commencement Date each of the Parties shall appoint one member to serve on the Dispute Adjudication Board (DAB). The Parties shall consult both these members and shall agree upon the third member, who shall be appointed to act as the chairman.</p> <p>The agreement between the Parties and each of the three members shall incorporate by reference the General Conditions of Dispute Adjudication Agreement contained in the Appendix to these Contract Data, with such amendments as are agreed between them.</p> <p>The terms of the remuneration of the three members, including the remuneration of any expert whom the DAB consults, shall be mutually agreed upon by the Parties when agreeing the terms of appointment of the member or such expert (as the case may be). Each Party shall be responsible for paying one-half of this remuneration</p> <p>If a member declines to act or is unable to act as a result of death, disability, resignation or termination of appointment, a replacement shall be appointed in the same manner as the replaced person was required to have been nominated or agreed upon, as described in this Sub-Clause.</p> <p>The appointment of any member may be terminated by mutual agreement of both Parties, but not by the Employer or the Contractor acting alone. Unless otherwise agreed by both Parties, the appointment of the DAB (including each member) shall expire when the discharge referred to in Sub-Clause 14.11 [Discharge] shall have become effective.</p>
-------------	--	---

19.3	Failure to Agree on the Composition of the Dispute Adjudication Board	<p>If any of the following conditions apply, namely:</p> <ul style="list-style-type: none"> (a) either Party fails to nominate a member of a DAB by such date, (b) the Parties fail to agree upon the appointment of the third member (to act as chairman) of the DAB by such date, or (c) the Parties fail to agree upon the appointment of a replacement person within 42 Days after the date on which the one of the three member declines to act or is unable to act as a result of death, disability, resignation or termination of appointment, <p>Then Institute for Construction Training and Development (ICTAD) shall, upon the request of either or both of the Parties and after due consultation with both Parties, appoint this member of the DAB. This appointment shall be final and conclusive. Each Party shall be responsible for paying one-half of the expenses / disbursements incurred by ICTAD.</p>
19.4	Obtaining Dispute Adjudication Board's Decision	<p>If a dispute (of any kind whatsoever) arises between the Parties in connection with, or arising out of, the Contract or the execution of the Works, including any dispute as to any certificate, determination, instruction, opinion or valuation of the Engineer, either Party may refer the dispute in writing to the DAB for its decision, with copies to the other Party and the Engineer. Such reference shall state that it is given under this Sub-Clause.</p> <p>The DAB shall be deemed to have received such reference on the date when it is received by the chairman of the DAB.</p> <p>Both Parties shall promptly make available to the DAB all such additional information, further access to the Site, and appropriate facilities, as the DAB may require for the purposes of making a decision on such dispute. The DAB shall be deemed to be not acting as arbitrator(s).</p>

		<p>Within 84 Days after receiving such reference, or within such other period as may be proposed by the DAB and approved by both Parties, the DAB shall give its decision, which shall be reasoned and shall state that it is given under this Sub-Clause. The decision shall be binding on both Parties, who shall promptly give effect to it unless and until it shall be revised in an amicable settlement or an arbitral award as described below. Unless the Contract has already been abandoned, repudiated or terminated, the Contractor shall continue to proceed with the Works in accordance with the Contract.</p> <p>If either Party is dissatisfied with the DAB’s decision, then either Party may, within 28 Days after receiving the decision, give notice to the other Party of its dissatisfaction and intention to commence arbitration. If the DAB fails to give its decision within the period of 84 Days (or as otherwise approved) after receiving such reference, then either Party may, within 28 Days after this period has expired, give notice to the other Party of its dissatisfaction and intention to commence arbitration.</p> <p>In either event, this notice of dissatisfaction shall state that it is given under this Sub-Clause, and shall set out the matter in dispute and the reason(s) for dissatisfaction. Except as stated in Sub-Clause 19.5 [Failure to Comply with Dispute Adjudication Board’s Decision] and Sub-Clause 19.6 [Expiry of Dispute Adjudication Board’s Appointment], neither Party shall be entitled to commence arbitration of a dispute unless a notice of dissatisfaction has been given in accordance with this Sub-Clause.</p> <p>If the DAB has given its decision as to a matter in dispute to both Parties, and no notice of dissatisfaction has been given by either Party within 28 Days after it received the DAB’s decision, then the decision shall become final and binding upon both Parties.</p>
19.5	Failure to Comply with Dispute Adjudication Board’s Decision	<p>In the event that a Party fails to comply with a DAB decision which has become final and binding, then the other Party may, without prejudice to any other rights it may have, refer the failure itself to arbitration under Sub-Clause 19.7 [Arbitration]. Sub-Clause 19.4 [Obtaining Dispute Adjudication Board’s Decision] shall not apply to this reference.</p>

19.6	Expiry of Dispute Adjudication Board's Appointment	<p>If a dispute arises between the Parties in connection with, or arising out of, the Contract or the execution of the Works and there is no DAB in place, whether by reason of the expiry of the DAB's appointment or otherwise:</p> <p>(a) Sub-Clause 19.4 [Obtaining Dispute Adjudication Board's Decision] shall not apply, and</p> <p>(b) the dispute may be referred directly to arbitration under Sub-Clause 19.7 [Arbitration].</p>
19.7	Arbitration	<p>(a) Any dispute of whatever nature arising from, out of or in connection with this agreement, on the interpretation thereof, or the rights, duties, obligations or liabilities of any Party, or the operation, breach, termination, abandonment, foreclosure or invalidity thereof, shall be referred to by either Party to arbitration for final settlement, in accordance with the Arbitration Act No. 11 of 1995, or any amendment thereof,</p> <p>(b) Pending the award in any arbitration proceedings hereunder,</p> <p>(i) this Contract and the rights and obligations of the Parties shall remain in full force and effect and</p> <p>(ii) each of the Parties shall continue to perform their respective obligations under this Contract. The termination of this Contract shall not result in the termination of any arbitration proceedings pending at the time of such termination nor otherwise affect the rights and obligations of the Parties under or with respect to such pending arbitration.</p> <p>(c) Any award rendered by the arbitral tribunal shall determine the extent to which the cost of arbitration is to be borne by each Party. The arbitration centre charges and the compensation to the arbitrator shall be equally shared by the Parties initially.</p>

		<p>Composition of the Arbitral Tribunal: The arbitral tribunal shall consist of a sole arbitrator who shall be appointed in the manner provided in the Selection Procedure as given below.</p> <p>Selection Procedure: The Party desiring arbitration shall nominate three arbitrators out of which one to be selected by the other Party within 21 Days of the receipt of such nomination. If the other Party does not select one to serve as Arbitrator within the stipulated period then the Arbitrator shall be appointed in accordance with the Arbitration Act No. 11 of 1995, or any amendments thereof.</p> <p>Venue & Language: The venue of arbitration shall be in Sri Lanka. Unless otherwise agreed to by the Parties the proceedings shall be conducted and the award shall be rendered in the English language.</p>
	<p>In the following sub-clauses, the term “Performance Security” is replaced with: “Performance Security and, if applicable, an Environmental, Social, Health and Safety (ESHS) Performance Security”:</p> <ul style="list-style-type: none"> 2.1- Right of Access to the Site 14.2- Advance Payment 14.5- Issue of Interim Payment Certificate 14.11- Discharge 15.5- Employer’s Entitlement to Termination for Convenience 16.4(a)- Payment on termination” 	

APPENDIX TO CONTRACT DATA

APPENDIX A

A General Conditions of Dispute Adjudication Agreement

1. Definitions

Each “Dispute Adjudication Agreement” is a tripartite agreement by and between:

- (a) the “Employer”;
- (b) the “Contractor”; and
- (c) the “Member” who is defined in the Dispute Adjudication Agreement as being one of the three persons who are jointly called the “DAB” (or “Dispute Adjudication Board”) and, where this is the case, the other two persons are called the “Other Members.”

The Employer and the Contractor have entered (or intend to enter) into a contract, which is called the "Contract" and is defined in the Dispute Adjudication Agreement, which incorporates this Appendix. In the Dispute Adjudication Agreement, words and expressions which are not otherwise defined shall have the meanings assigned to them in the Contract.

2. General Provisions

Unless otherwise stated in the Dispute Adjudication Agreement, it shall take effect on the latest of the following dates:

- (a) the Commencement Date defined in the Contract,
- (b) when the Employer, the Contractor and the Member have each signed the Dispute Adjudication Agreement, or
- (c) when the Employer, the Contractor and each of the Other Members have respectively each signed a Dispute Adjudication Agreement.

This employment of the Member is a personal appointment. At any time, the Member may give not less than 70 Day notice of resignation to the Employer and to the Contractor, and the Dispute Agreement shall terminate upon the expiry of this period.

3. Warranties

The Member warrants and agrees that he/she is and shall be impartial and independent of the Employer, the Contractor and the Engineer. The Member shall promptly disclose, to each of them and to the Other Members, any fact or circumstance which might appear inconsistent with his/her warranty and agreement of impartiality and independence.

When appointing the Member, the Employer and the Contractor relied upon the Member’s representations that he/she is:

- (a) experienced in the work which the Contractor is to carry out under the Contract,
- (b) experienced in the interpretation of contract documentation, and
- (c) fluent in the language for communications defined in the Contract.

4. General Obligations of the Member

The Member shall:

- (a) have no interest financial or otherwise in the Employer, the Contractor or Engineer, nor any financial interest in the Contract except for payment under the Dispute Adjudication Agreement;
- (b) not previously have been employed as a consultant or otherwise by the Employer, the Contractor or the Engineer, except in such circumstances as were disclosed in writing to the Employer and the Contractor before they signed the Dispute Adjudication Agreement;
- (c) have disclosed in writing to the Employer, the Contractor and the Other Members, before entering into the Dispute Adjudication Agreement and to his/her best knowledge and recollection, any professional or personal relationships with any director, officer or employee of the Employer, the Contractor or the Engineer, and any previous involvement in the overall project of which the Contract forms part;
- (d) not, for the duration of the Dispute Adjudication Agreement, be employed as a consultant or otherwise by the Employer, the Contractor or the Engineer, except as may be agreed in writing by the Employer, the Contractor and the Other Members;
- (e) comply with the annexed procedural rules and with Sub-Clause 19.4 (Obtaining Dispute Adjudication Board's Decision) of the Conditions of Contract;
- (f) not give advice to the Employer, the Contractor, the Employer's Personnel or the Contractor's Personnel concerning the conduct of the Contract, other than in accordance with the annexed procedural rules;
- (g) not while a Member enter into discussions or make any agreement with the Employer, the Contractor or the Engineer regarding employment by any of them, whether as a consultant or otherwise, after ceasing to act under the Dispute Adjudication Agreement;
- (h) ensure his/her availability for all site visits and hearings as are necessary;
- (i) become conversant with the Contract and with the progress of the Works (and of any other parts of the project of which the Contract forms part) by studying all documents received which shall be maintained in a current working file;
- (j) treat the details of the Contract and all the DAB's activities and hearings as private and confidential, and not publish or disclose them without the prior written consent of the Employer, the Contractor and the Other Members; and
- (k) be available to give advice and opinions, on any matter relevant to the Contract when requested by both the Employer and the Contractor, subject to the agreement of the Other Members.

5. General Obligations of the Employer and the Contractor

The Employer, the Contractor, the Employer's Personnel and the Contractor's Personnel shall not request advice from or consultation with the Member regarding the Contract, otherwise than in the normal course of the DAB's activities under the Contract and the Dispute Adjudication Agreement. The Employer and the Contractor shall be responsible for compliance with this provision, by the Employer's Personnel and the Contractor's Personnel respectively.

The Employer and the Contractor undertake to each other and to the Member that the Member shall not, except as otherwise agreed in writing by the Employer, the Contractor, the Member and the Other Members:

- (a) be appointed as an arbitrator in any arbitration under the Contract;
- (b) be called as a witness to give evidence concerning any dispute before arbitrator(s) appointed for any arbitration under the Contract; or
- (c) be liable for any claims for anything done or omitted in the discharge or purported discharge of the Member's functions, unless the act or omission is shown to have been in bad faith.

The Employer and the Contractor hereby jointly and severally indemnify and hold the Member harmless against and from claims from which he is relieved from liability under the preceding paragraph.

Whenever the Employer or the Contractor refers a dispute to the DAB under Sub-Clause 19.4 (Obtaining Dispute Adjudication Board's Decision) of the Conditions of Contract, which will require the Member to make a site visit and attend a hearing, the Employer or the Contractor shall provide appropriate security for a sum equivalent to the reasonable expenses to be incurred by the Member. No account shall be taken of any other payments due or paid to the Member.

6. Payment

The Member shall be paid as follows:

- (a) a retainer fee per calendar month, which shall be considered as payment in full for:
 - (i) being available on 28 Day notice for all site visits and hearings;
 - (ii) becoming and remaining conversant with all project developments and maintaining relevant files;
 - (iii) all office and overhead expenses including secretarial services, photocopying and office supplies incurred in connection with his duties; and
 - (iv) all services performed hereunder except those referred to in subparagraphs (b) and (c) of this Clause.

The retainer fee shall be paid with effect from the last day of the calendar month in which the Dispute Adjudication Agreement becomes effective; until the last day of the calendar month in which the Taking-Over Certificate is issued for the whole of the Works.

With effect from the first day of the calendar month following the month in which the Taking-Over Certificate is issued for the whole of the Works, the retainer fee shall be reduced by 50%. This reduced fee shall be paid until the first day of the calendar month in which the Member resigns or the Dispute Adjudication Agreement is otherwise terminated.

- (b) a daily fee which shall be considered as payment in full for:
 - (i) each day or part of a day up to a maximum of two Days travel time in each direction for the journey between the Member's home and the site, or another location of a meeting with the Other Members;
 - (ii) each working day on Site visits, hearings or preparing decisions; and
 - (iii) each day spent reading submissions in preparation for a hearing.
- (c) all reasonable expenses including necessary travel expenses (hotel and subsistence and other direct travel expenses) incurred in connection with the Member's duties, as well as the cost of telephone calls, courier charges, and faxes: a receipt shall be required for each item in excess of five percent of the daily fee referred to in sub-paragraph (b) of this Clause.

The retainer and daily fees shall be as specified in the Dispute Adjudication Agreement. Unless it specifies otherwise, these fees shall remain fixed for the entire duration of the Contract.

The Member shall submit invoices for payment of the monthly retainer quarterly in advance. Invoices for other expenses and for daily fees shall be submitted following the conclusion of a site visit or hearing. All invoices shall be accompanied by a brief description of activities performed during the relevant period and shall be addressed to the Contractor.

The Contractor shall pay each of the Member's invoices in full within 56 calendar days after receiving each invoice and shall apply to the Employer (in the Statements under the Contract) for reimbursement of one-half of the amounts of these invoices. The Employer shall then pay the Contractor in accordance with the Contract.

If the Contractor fails to pay to the Member the amount to which he/she is entitled under the Dispute Adjudication Agreement, the Employer shall pay the amount due to the Member and any other amount which may be required to maintain the operation of the DAB; and without prejudice to the Employer's rights or remedies. In addition to all other rights arising from this default, the Employer shall be entitled to reimbursement of all sums paid in excess of one-half of these payments, plus all costs of recovering these sums and financing charges calculated at the rate specified in Sub-Clause 14.7 of the Conditions of Contract.

If the Member does not receive payment of the amount due within 70 days after submitting a valid invoice, the Member may (i) suspend his/her services (without notice) until the payment is received, and/or (ii) resign his/her appointment by giving notice under Clause 7.

7. Termination

At any time: (i) the Employer and the Contractor may jointly terminate the Dispute Adjudication Agreement by giving 42 Day notice to the Member; or (ii) the Member may resign as provided for in Clause 2.

If the Member fails to comply with the Dispute Adjudication Agreement, the Employer and the Contractor may, without prejudice to their other

rights, terminate it by notice to the Member. The notice shall take effect when received by the Member.

If the Employer or the Contractor fails to comply with the Dispute Adjudication Agreement, the Member may, without prejudice to his other rights, terminate it by notice to the Employer and the Contractor. The notice shall take effect when received by them both.

Any such notice, resignation and termination shall be final and binding on the Employer, the Contractor and the Member. However, a notice by the Employer or the Contractor, but not by both, shall be of no effect.

8. Default of the Member

If the Member fails to comply with any of his obligations under Clause 4 (a) - (d) above, he shall not be entitled to any fees or expenses hereunder and shall, without prejudice to their other rights, reimburse each of the Employer and the Contractor for any fees and expenses received by the Member and the Other Members, for proceedings or decisions of the DAB which are rendered void or ineffective by the said failure to comply.

If the Member fails to comply with any of his obligations under Clause 4 (e) - (k) above, he shall not be entitled to any fees or expenses hereunder from the date and to the extent of the non-compliance and shall, without prejudice to their other rights, reimburse each of the Employer and the Contractor for any fees and expenses already received by the Member, for proceedings or decisions of the DAB which are rendered void or ineffective by the said failure to comply.

9. Disputes

Any dispute or claim arising out of or in connection with this Dispute Adjudication Agreement, or the breach, termination or invalidity thereof, shall be finally settled in accordance with Arbitration Act No 11, 1995 of Sri Lanka with a sole Arbitrator..

Reference

PROCEDURAL RULES

1. Unless otherwise agreed by the Employer and the Contractor, the DAB shall visit the site at intervals of not more than 70 days, including times of critical construction events, at the request of either the Employer or the Contractor. Unless otherwise agreed by the Employer, the Contractor and the DAB, the period between consecutive visits shall not be less than 35 days, except as required to convene a hearing as described below.
2. The timing of and agenda for each site visit shall be as agreed jointly by the DAB, the Employer and the Contractor, or in the absence of agreement, shall be decided by the DAB. The purpose of site visits is to enable the DAB to become and remain acquainted with the progress of the Works and of any actual or potential problems or claims, and, as far as reasonable, to endeavor to prevent potential problems or claims from becoming disputes.
3. Site visits shall be attended by the Employer, the Contractor and the Engineer and shall be co-ordinated by the Employer in co-operation with the Contractor. The Employer shall ensure the provision of appropriate conference facilities and secretarial and copying services. At the conclusion of each site visit and before leaving the site, the DAB shall prepare a report on its activities during the visit and shall send copies to the Employer and the Contractor.
4. The Employer and the Contractor shall furnish copy each to the members of the DAB all documents which the DAB may request, including Contract documents, progress reports, variation instructions, certificates and other documents pertinent to the performance of the Contract. All communications between the DAB and the Employer or the Contractor shall be copied to the other Party.
5. If any dispute is referred to the DAB in accordance with Sub-Clause 19.4 (Obtaining Dispute Adjudication Board's Decision) of the Conditions of Contract, the DAB shall proceed in accordance with Sub-Clause 19.4 (Obtaining Dispute Adjudication Board's Decision) and these Rules. Subject to the time allowed to give notice of a decision and other relevant factors, the DAB shall:
 - (a) act fairly and impartially as between the Employer and the Contractor, giving each of them a reasonable opportunity of putting his case and responding to the other's case, and
 - (b) adopt procedures suitable to the dispute, avoiding unnecessary delay or expense.
6. The DAB may conduct a hearing on the dispute, in which event it will decide on the date and place for the hearing and may request that written documentation and arguments from the Employer and the Contractor be presented to it prior to or at the hearing.
7. Except as otherwise agreed in writing by the Employer and the Contractor, the DAB shall have power to adopt an inquisitorial procedure, to refuse admission to hearings or audience at hearings to any persons other than representatives of the Employer, the Contractor and the Engineer, and to proceed in the absence of any party who the DAB is satisfied received notice of the hearing; but shall have discretion to decide whether and to what extent this power may be exercised.
8. The Employer and the Contractor empower the DAB, among other things, to:
 - (a) establish the procedure to be applied in deciding a dispute,
 - (b) decide upon the DAB's own jurisdiction, and as to the scope of any dispute referred to it,
 - (c) conduct any hearing as it thinks fit, not being bound by any rules or procedures other than those contained in the Contract and these Guidelines,

- (d) take the initiative in ascertaining the facts and matters required for a decision,
 - (e) make use of its own specialist knowledge, if any,
 - (f) decide upon the payment of financing charges in accordance with the Contract,
 - (g) decide upon any provisional relief such as interim or conservatory measures, and
 - (h) open up, review and revise any certificate, decision, determination, instruction, opinion or valuation of the Engineer, relevant to the dispute.
9. The DAB shall not express any opinions during any hearing concerning the merits of any arguments advanced by the Parties. Thereafter, the DAB shall make and give its decision in accordance with Sub-Clause 19.4 (Obtaining Dispute Adjudication Board's Decision), or as otherwise agreed by the Employer and the Contractor in writing. The DAB:
- (a) shall convene in private after a hearing, in order to have discussions and prepare its decision;
 - (b) shall endeavor to reach a unanimous decision: if this proves impossible the applicable decision shall be made by a majority of the Members, who may require the minority Member to prepare a written report for submission to the Employer and the Contractor; and
 - (c) Member fails to attend a meeting or hearing, or to fulfill any required function, the other two Members may nevertheless proceed to make a decision, unless:
 - (i) either the Employer or the Contractor does not agree that they do so, or
 - (ii) the absent Member is the chairman and he/she instructs the other Members to not make a decision.

DISPUTE ADJUDICATION AGREEMENT

[for each member of a three - person DAB]

Name and details of Contract
Name and address of Employer
Name and address of Contractor
Name and address of Member

Whereas the Employer and the Contractor have entered into the Contract and desire jointly to appoint the Member to act as one of the three persons who are jointly called the Dispute Adjudication Board (DAB) [and desire the Member to act as chairman of the DAB]

The Employer, Contractor and Member jointly agree as follows:

1. The conditions of this Dispute Adjudication Agreement comprise the “General Conditions of Dispute Adjudication Agreement” which is appended to the General Conditions of the “Standard Bidding Document, Procurement of Works, Major Contracts - Second Edition, January 2007” and the following provisions. In these provisions, which include amendments and additions to the General Conditions of Dispute Adjudication Agreement, words and expressions shall have the same meanings as are assigned to them in the General Conditions of Dispute Adjudication Agreement.

2. [Details of amendments to the General Conditions of Dispute Adjudication Agreement, if any

For example:

In the procedural rules annexed to the General Conditions of Dispute Adjudication Agreement, Rule _____ is deleted and replaced by: “.....”]

3 In accordance with Clause 6 of the General Conditions of Dispute Adjudication Agreement the Member shall be paid as follows:

A retainer fee of _____ per calendar month,
plus, a daily fee of _____ per day.

4 In consideration of these fees and other payments to be made by the Employer and the Contractor in accordance with Clause 6 of the General Conditions of Dispute Adjudication Agreement, the Member undertakes to serve, as described in this Dispute Adjudication Agreement, as one of the three persons who are jointly to act as the DAB.

5 The Employer and the Contractor jointly and severally undertake to pay the Member, in consideration of the carrying out of these services, in accordance with Clause 6 of the General Conditions of Dispute Adjudication Agreement.

6 This Dispute Adjudication Agreement shall be governed by the law of _____

SIGNED by: _____ SIGNED by: _____ SIGNED by: _____

for and on behalf of the employer for and on behalf of the Contractor the Member
in the presence of in the presence of in the presence of

Witness: _____ Witness: _____ Witness : _____

Name: _____ Name: _____ Name : _____

Address: _____ Address: _____ Address : _____

Date: _____ Date: _____ Date: _____

APPENDIX B

Environmental, Social, Health and Safety (ESHS)

Metrics for Progress Reports

Metrics for regular reporting:

- a. *environmental incidents or non-compliances with contract requirements, including contamination, pollution or damage to ground or water supplies;*
- b. *health and safety incidents, accidents, injuries and all fatalities that require treatment;*
- c. *interactions with regulators: identify agency, dates, subjects, outcomes (report the negative if none);*
- d. *status of all permits and agreements:*
 - i. *work permits: number required, number received, actions taken for those not received;*
 - ii. *status of permits and consents:*
 - *List areas/facilities with permits required (quarries, asphalt & batch plants), dates of application, dates issued (actions to follow up if not issued), dates submitted to resident engineer (or equivalent), status of area (waiting for permits, working, abandoned without reclamation, decommissioning plan being implemented, etc.);*
 - *list areas with landowner agreements required (borrow and spoil areas, camp sites), dates of agreements, dates submitted to resident engineer (or equivalent);*
 - *identify major activities undertaken in each area in the reporting period and highlights of environmental and social protection (land clearing, boundary marking, topsoil salvage, traffic management, decommissioning planning, decommissioning implementation);*
 - *for quarries: status of relocation and compensation (completed, or details of activities and current status in the reporting period).*
- e. *health and safety supervision:*
 - i. *safety officer: number days worked, number of full inspections & partial inspections, reports to construction/project management;*
 - ii. *number of workers, work hours, metric of PPE use (percentage of workers with full personal protection equipment (PPE), partial, etc.), worker violations observed (by type of violation, PPE or otherwise), warnings given, repeat warnings given, follow-up actions taken (if any);*
- f. *worker accommodations:*
 - i. *number of expats housed in accommodations, number of locals;*

- ii. date of last inspection, and highlights of inspection including status of accommodations' compliance with national and local law and good practice, including sanitation, space, etc.;
- iii. actions taken to recommend/require improved conditions, or to improve conditions.
- g. *HIV/AIDS: provider of health services, information and/or training, location of clinic, number of non-safety disease or illness treatments and diagnoses (no names to be provided);*
- h. *gender (for expats and locals separately): number of female workers, percentage of workforce, gender issues raised and dealt with (cross-reference grievances or other sections as needed);*
- i. *training:*
 - i. number of new workers, number receiving induction training, dates of induction training;
 - ii. number and dates of toolbox talks, number of workers receiving Occupational Health and Safety (OHS), environmental and social training;
 - iii. number and dates of HIV/AIDS sensitization and/or training, no. workers receiving training (in the reporting period and in the past); same questions for gender sensitization, flag person training.
 - iv. number and date of GBV /SEA sensitization and/or training, number of workers receiving training on code of conduct (in the reporting period and in the past), etc.
- j. *environmental and social supervision:*
 - i. environmentalist: days worked, areas inspected and numbers of inspections of each (road section, work camp, accommodations, quarries, borrow areas, spoil areas, swamps, forest crossings, etc.), highlights of activities/findings (including violations of environmental and/or social best practices, actions taken), reports to environmental and/or social specialist/construction/site management;
 - ii. sociologist: days worked, number of partial and full site inspections (by area: road section, work camp, accommodations, quarries, borrow areas, spoil areas, clinic, HIV/AIDS center, community centers, etc.), highlights of activities (including violations of environmental and/or social requirements observed, actions taken), reports to environmental and/or social specialist/construction/site management; and
 - iii. Community liaison person(s): days worked (hours community center open), number of people met, highlights of activities (issues raised, etc.), reports to environmental and/or social specialist /construction/site management.
- k. *Grievances: list new grievances (e.g. allegations of GBV / SEA) received in the reporting period and unresolved past grievances by date received, complainant, how received, to whom referred to for action, resolution and date (if completed), data resolution reported to complainant, any required follow-up (Cross-reference other sections as needed):*
 - i. Worker grievances;

- ii. Community grievances
- l. *Traffic and vehicles/equipment:*
 - i. traffic accidents involving project vehicles & equipment: provide date, location, damage, cause, follow-up;
 - ii. accidents involving non-project vehicles or property (also reported under immediate metrics): provide date, location, damage, cause, follow-up;
 - iii. overall condition of vehicles/equipment (subjective judgment by environmentalist); non-routine repairs and maintenance needed to improve safety and/or environmental performance (to control smoke, etc.).
- m. *Environmental mitigations and issues (what has been done):*
 - i. dust: number of working bowsers, number of waterings/day, number of complaints, warnings given by environmentalist, actions taken to resolve; highlights of quarry dust control (covers, sprays, operational status); % of rock/spoil lorries with covers, actions taken for uncovered vehicles;
 - ii. erosion control: controls implemented by location, status of water crossings, environmentalist inspections and results, actions taken to resolve issues, emergency repairs needed to control erosion/sedimentation;
 - iii. quarries, borrow areas, spoil areas, asphalt plants, batch plants: identify major activities undertaken in the reporting period at each, and highlights of environmental and social protection: land clearing, boundary marking, topsoil salvage, traffic management, decommissioning planning, decommissioning implementation;
 - iv. blasting: number of blasts (and locations), status of implementation of blasting plan (including notices, evacuations, etc.), incidents of off-site damage or complaints (cross-reference other sections as needed);
 - v. spill cleanups, if any: material spilled, location, amount, actions taken, material disposal (report all spills that result in water or soil contamination);
 - vi. waste management: types and quantities generated and managed, including amount taken offsite (and by whom) or reused/recycled/disposed on-site;
 - vii. details of tree plantings and other mitigations required undertaken in the reporting period;
 - viii. details of water and swamp protection mitigations required undertaken in the reporting period.
- n. *compliance:*
 - i. compliance status for conditions of all relevant consents/permits, for the Work, including quarries, etc.): statement of compliance or listing of issues and actions taken (or to be taken) to reach compliance;
 - ii. compliance status of C-ESMP/ESIP requirements: statement of compliance or listing of issues and actions taken (or to be taken) to reach compliance

- iii. compliance status of GBV/SEA prevention and response action plan: statement of compliance or listing of issues and actions taken (or to be taken) to reach compliance
- iv. compliance status of Health and Safety Management Plan re: statement of compliance or listing of issues and actions taken (or to be taken) to reach compliance
- v. other unresolved issues from previous reporting periods related to environmental and social: continued violations, continued failure of equipment, continued lack of vehicle covers, spills not dealt with, continued compensation or blasting issues, etc. Cross-reference other sections as needed.

Reference Only

Section - 5

Standard Forms (Contract)

- Letter of Acceptance
- Agreement
- Performance Security
- ESHS Performance Security
- Advance Payment Security
- Retention Money Guarantee
- ESHS Declaration

Notes on Form of Letter of Acceptance

The Letter of Acceptance will be the basis for formation of the Contract as described in Clause 34 of the Instructions to Bidders. This Form of Letter of Acceptance should be filled in and sent to the successful bidder only after evaluation of Bids and after obtaining approval from the relevant authority.

FORM OF LETTER OF ACCEPTANCE

[Letter heading paper of the procuring entity]

..... [date]

To: ----- [name and address of the Contractor] -----

This is to notify you that your bid dated ----- [insert date] for the construction and remedying defects of the Improvements to Sinnanai Anicut with gate arrangements in Ampara District . LK-MOMDE-539131-CW-RFB for the Contract price of -----[name of currency] ----- [amount in figures and words] as corrected in accordance with Instructions to Bidders and/ or modified by a Memorandum of Understanding' is hereby accepted.

You are hereby instructed to proceed with the execution of the said Works in accordance with the Contract documents.

The Commencement Date shall be: (fill the date as per Clause 8.1 of Conditions of Contract).

The amount of Performance Security is: (fill the amount as per Clause 4.2 of Conditions of Contract).

The Performance Security shall be submitted on or before (fill the date as per Clause 4.2 of Conditions of Contract).

Authorized Signature :

Name and title of Signatory:

**FORM OF PERFORMANCE SECURITY
(Unconditional)**

----- *[Issuing Agency's Name, and Address of Issuing Branch or Office]* -----

Beneficiary: ----- *[Name and Address of Employer]*

Date: -----

PERFORMANCE GUARANTEE No.: -----

We have been informed that ----- *[name of Contractor]* (hereinafter called "the Contractor") has entered into Contract No. LK-MOMDE-539131-CW-RFB dated ----- with you, for the ----- *[insert "construction"]* of the Improvements to Sinnanai Anicut with gate arrangements in Ampara District .(hereinafter called "the Contract").

Furthermore, we understand that, according to the Conditions of the Contract, a performance guarantee is required.

At the request of the Contractor, we ----- *[name of Agency]* hereby irrevocably undertake to pay you any sum or sums not exceeding in total an amount of ----- *[amount in figures]* (-----) *[amount in words]*, upon receipt by us of your first demand in writing accompanied by a written statement stating that the Contractor is in breach of its obligation(s) under the Contract, without your needing to prove or to show grounds for your demand or the sum specified therein.

This guarantee shall expire, no later than the day of, 20.. *[insert date, 28 days beyond the Time for Completion]* and any demand for payment under it must be received by us at this office on or before that date.

[signature(s)]

Form of Environmental, Social, Health and safety (ESHS) Performance Security

ESHS Demand Guarantee

[Guarantor letterhead or SWIFT identifier code]

Beneficiary: *[insert name and Address of Employer]***Date:** _ *[Insert date of issue]*

ESHS PERFORMANCE GUARANTEE No.: *[Insert guarantee reference number]*

Guarantor: *[Insert name and address of place of issue, unless indicated in the letterhead]*

We have been informed that _____ (hereinafter called "the Applicant") has entered into Contract No. _____ dated _____ with the Beneficiary, for the execution of _____ (hereinafter called "the Contract").

Furthermore, we understand that, according to the conditions of the Contract, a performance guarantee is required. At the request of the Applicant, we as Guarantor, hereby irrevocably undertake to pay the Beneficiary any sum or sums not exceeding in total an amount of _____ (_____),¹ such sum being payable in the types and proportions of currencies in which the Contract Price is payable, upon receipt by us of the Beneficiary's complying demand supported by the Beneficiary's statement, whether in the demand itself or in a separate signed document accompanying or identifying the demand, stating that the Applicant is in breach of its Environmental and/or Social and/or Health and/or Safety (ESHS) obligation(s) under the Contract, without the Beneficiary needing to prove or to show grounds for your demand or the sum specified therein. This guarantee shall expire, no later than the Day of, 2...², and any demand for payment under it must be received by us at this office indicated above on or before that date.

This guarantee is subject to the Uniform Rules for Demand Guarantees (URDG) 2010 Revision, ICC Publication No. 758, except that the supporting statement under Article 15(a) is hereby excluded.

[signature(s)]

Note: All italicized text (including footnotes) is for use in preparing this form and shall be deleted from the final product.

¹ The Guarantor shall insert an amount representing the percentage of the Accepted Contract Amount specified in the Letter of Acceptance, less provisional sums, if any, and denominated either in the currency (cies) of the Contract or a freely convertible currency acceptable to the Beneficiary.

² Insert the date twenty-eight days after the expected completion date as described in GC Clause 11.9. The Employer should note that in the event of an extension of this date for completion of the Contract, the Employer would need to request an extension of this guarantee from the Guarantor. Such request must be in writing and must be made prior to the expiration date established in the guarantee. In preparing this guarantee, the Employer might consider adding the following text to the form, at the end of the penultimate paragraph: "The Guarantor agrees to a one-time extension of this guarantee for a period not to exceed [six months] [one year], in response to the Beneficiary's written request for such extension, such request to be presented to the Guarantor before the expiry of the guarantee."

FORM OF ADVANCE PAYMENT SECURITY

----- [Name and address of Agency, and Address of Issuing Branch or Office] -----

Beneficiary: ----- [Name and Address of Employer]

Date: -----

ADVANCE PAYMENT GUARANTEE No.: -----

We have been informed that ----- [name of Contractor] (hereinafter called “the Contractor”) has entered into Contract No. LK-MOMDE-539131-CW-RFB dated ----- with you, for the ----- construction of the Improvements to Sinnanai Anicut with gate arrangements in Ampara District. (hereinafter called "the Contract").

Furthermore, we understand that, according to the conditions of the Contract, an advance payment in the sum ----- [amount in figures] (-----) [amount in words] is to be made against an advance payment guarantee.

At the request of the Contractor, we ----- [name of issuing agency] hereby irrevocably undertake to pay you any sum or sums not exceeding in total an amount of ----- [amount in figures] (-----) [amount in words] upon receipt by us of your first demand in writing accompanied by a written statement stating that the Contractor is in breach of its obligation in repayment of the Advance Payment under the Contract.

The maximum amount of this guarantee shall be progressively reduced by the amount of the advance payment repaid by the Contractor.

This guarantee shall expire on [Insert the date, 28 days beyond the Time of Completion]

Consequently, any demand for payment under this guarantee must be received by us at this office on or before that date.

[signature(s)]

FORM OF RETENTION MONEY GUARANTEE

----- *[Issuing Agency's Name, and Address of Issuing Branch or Office]* -----

Beneficiary: ----- *[Name and Address of Employer]* -----

Date: -----

RETENTION MONEY GUARANTEE No.: -----

We have been informed that ----- *[name of Contractor]* (hereinafter called "the Contractor") has entered into Contract No. LK-MOMDE-539131-CW-RFB *[reference number of the contract]* dated ----- with you, for the execution of the Improvements to Sinnanai Anicut with gate arrangements in Ampara District. *[name of contract and brief description of Works]* (hereinafter called "the Contract").

Furthermore, we understand that, according to the conditions of the Contract, when the works have been taken over and the first half of the Retention Money has been certified for payment, payment of the second half of the Retention Money may be made against a Retention Money guarantee.

At the request of the Contractor, we ----- *[name of agency]* hereby irrevocably undertake to pay you any sum or sums not exceeding in total an amount of ----- *[amount in figures]* (-----) *[amount in words]* upon receipt by us of your first demand in writing accompanied by a written statement stating that the Contractor is in breach of its obligation under the Contract because the Contractor has not attended to the defects in accordance with the Contract..

This guarantee shall expire, at the latest, ----- *[insert 28 Days after the end of the Defects Liability Period]*. Consequently, any demand for payment under this guarantee must be received by us at this office on or before that date.

[signature(s)]

Form of ESHS Declaration

Date: _____
 Bid No.: _____

To: _____

We, the undersigned, declare that civil work contracts *have/ have not been* suspended or terminated and/or performance security called by an employer for reasons related to the non-compliance of any environmental, or social, (including sexual exploitation and abuse (SEA) and gender based violence (GBV)), or health or safety requirements or safeguard in the past five years.

(Note: If suspended, terminated or Performance Security is called give details)

Year	Suspended or terminated portion of contract	Contract Identification	Total Contract Amount (current value, currency, exchange rate and US\$ equivalent)
<i>[insert year]</i>	<i>[insert amount and percentage]</i>	Contract Identification: <i>[indicate complete contract name/ number, and any other identification]</i> Name of Employer: <i>[insert full name]</i> Address of Employer: <i>[insert street/city/country]</i> Reason(s) for suspension or termination: <i>[indicate main reason(s) e.g. for GBV/ SEA breaches]</i>	<i>[insert amount]</i>
...	...	<i>[list all applicable contracts]</i>	...

Performance Security called by an employer(s) for reasons related to ESHS performance

Year	Contract Identification	Total Contract Amount (current value, currency, exchange rate and US\$ equivalent)
<i>[insert year]</i>	Contract Identification: <i>[indicate complete contract name/ number, and any other identification]</i> Name of Employer: <i>[insert full name]</i> Address of Employer: <i>[insert street/city/country]</i> Reason(s) for calling of performance security: <i>[indicate main reason(s) e.g. for GBV/ SEA breaches]</i>	<i>[insert amount]</i>

Signed: _____

In the capacity of _____

Name: _____

Duly authorized to sign the bid for and on behalf of: _____

Dated on _____ day of _____, _____

Corporate Seal (where appropriate)

Section - 6

Specifications

Reference Only

Specifications

Technical Specifications relevant to this contract consists of two parts.

Part 1 - General Technical Specifications

The following specifications published by the Institute for Construction, Training and Development (ICTAD) are applicable as General Specifications for this Contract.

CIDA/SP/102	Irrigation & Land Drainage -- [1st Edition – January 2017]
SCA/4/I	Building Works (Vol. I) – [3rd Edition (Revised) – July 2004]
SCA/4/II	Building Works (Vol. II) – [2nd Edition (Revised) – October 2001]
SCA/5	Standard Specifications for Construction and Maintenance of Roads and Bridges

These publications are not issued with this Bidding Document and the Bidder shall purchase the same from CIDA.

Part 2 - Particular Technical Specifications

Particular Technical Specifications includes project specific specifications and conditions of particular specification which includes modifications and amplifications to the Standard Specifications given in General Technical Specifications.

1. Introduction

The following Particular Technical Specifications are part of the requirements for the work related the Civil Works which are to be provided according to the stipulation of the Contract. Hence, the instructions given herein form an integral part of the, and are applicable to, all technical and Contract documents issued for Works. Addenda to these specifications may be issued as required during construction phase.

These Particular Technical Specifications shall be read in conjunction with the General Technical Specifications (ICTAD), the Conditions of Contract and the Bidding Drawings. The Contractor shall comply with all provisions contained within Contract documents.

The General Technical specifications and the Particular Technical Specifications in conjunction with the Bidding drawings define the technical standard and quality to be achieved during construction.

The Particular Technical Specifications relevant to this contract are given in following Sub Sections.

Description	Sub Section
Land Available	2
Road Access to Site	3
Contract Documents and Drawings	4
Schedules and Reports	5
Use of Construction Facilities and Works Area	6

Contractor's Equipment	7
Standards	8
Setting out Works	9
Safety Precautions	10
Temporary Works	11
Contractor's Offices, Camp and Facilities	12
Inspections and Material Testing Laboratory	13
Quality Assurance System	14
Dealing with Water	15
Tests for Borrow areas and Quarries	16
Specification toe Drain	17
Embankment Filling	18
Rip Rap for Protection Upstream Face of Dam	19
Environmental and social Management plan	
Standard Procedure for Ensuring Occupational Health and Safety When working in Wildlife Area	21
Standard Procedure for Assessing the Requirement of Tree Removals	22
Covid 19 Safety Manual	23

2. Land Available

The land available to the Contractor free of charge for the duration of the Contract shall be as follows:

- a. The land occupied by the Permanent Works;
- b. The Contractor is responsible for find out suitable barrow area for obtaining the necessary approvals for mining and transport.
- c. The land as approved by the Engineer for Contractor's housing, plant-yards, workshops and offices, after approval has been given for the locations and layouts of such installations.

3. Road Access to the Site

3.1 Transport of Materials

Prior to moving any heavy construction traffic onto highways, roads and bridges, the Contractor shall make suitable arrangements with the appropriate Government Authorities and obtain their approval for the passage of such traffic.

3.2 Special Protection

Where Government Authorities require and specify any special protection or strengthening of highways, roads and bridges. The Contractor shall submit to the Engineer his proposals for such work after their approval by the authority concerned and shall carry-out this work as directed.

3.3 Tracked Vehicles

The Contractor shall not travel tracked vehicles or plant on any bituminous sealed road surface. Rubber-tyred vehicles conforming to applicable load restrictions will be permitted to use bituminous sealed roads.

3.4 Construction of Additional Roads

The Contractor shall design, construct and maintain all temporary access and haul roads to, in, and around his camp area, the various working sites and designated borrow and disposal areas, required for the Works. These roads shall include all associated drainage and stream crossing facilities. The location of these roads shall be in accordance with the Contractor's proposals submitted with his Tender.

During the period of the Contract, the Contractor shall allow the Employer and such other parties free and unrestricted use of all access and haul roads and shall not restrict the access of authorized persons to these roads, look-outs or viewing points as may be instructed.

4. Contract Documents and Drawings

4.1 Contract Documents

The Contractor will be provided with one set of the Contract Documents for his own use. A complete set of Contract Documents supplied by the Engineer and all further instructions issued by him shall be kept at all times by the Contractor on the Site and made available to the Engineer and his staff.

4.2 Construction Drawings

Based on Tender drawings issued, the Contractor shall prepare and submit all construction and shop drawings. All Contractor's working drawings and shop drawings required to be submitted for approval in accordance with the Specification, shall be provided in electronic format (AutoCAD computer software) and 03 printed copies, plus copies of design calculations where required, specification and parts catalogues in duplicate. All drawings and calculations submitted for approval shall be signed, checked and approved by the Contractor prior to submission. The drawings and calculations shall be signed by a qualified Engineer responsible for the design.

Within 30 days after receiving such designs, design calculations, parts catalogues, specifications and detailed drawings, the Engineer shall give his approval or request modifications. The Contractor shall modify the design and drawings as may be required by the Engineer.

The work shall be constructed in accordance with the approved drawings, and a copy of such drawings shall be kept on the Site at all times until the completion of the Contract. All drawings on which changes are made shall have the revisions clearly marked.

Construction, fabrication or manufacture of any portion of the Works shall not commence until the design and drawings have been approved in writing by the Engineer and thereafter no change shall be made to any drawings so approved without the permission of the Engineer. Permission to make such changes shall be requested by sending 01 electronic copy and 01 print of each revised drawing to the Engineer for approval.

4.3 As-built Drawings

The Contractor shall submit the 4 copies of "As-built Drawings" on a format agreed between the Contractor and Engineer.

These As-built drawings shall be prepared from the Construction drawings incorporating any authorized changes carried out during construction. Once completed these drawings shall become the property of the Employer and shall be submitted before issue of the Taking -over certificate.

5. Schedules and Reports

5.1 Construction and Contractual Program

- a. Within 01 month of the award of Contract, the Contractor shall submit a revision of the construction program attached to the Tender, for approval.

The construction program shall be prepared using the latest computer software such as MS Project or other similar software approved by the Engineer. This program in bar chart form shall outline the Contractor's activities necessary to complete the Works within the period required for completion. The program shall show the following minimum details:

- The duration, sequence and logic links between major activities and any other activities or group of activities which comprise the Works, necessary to define the critical path and logic of the program required for completion and to achieve the Time for Completion. For the purpose of this clause, major activities are those which are greater than one percent of the Contract Price;
- The planned dates for start and completion of the Works and each Section of the Works;
- The critical path(s) for the Works and each Section of the Works;
- Information on shutdown periods, vacation days and other non-working time periods;
- The estimated value of work to be done each month;
- Reasons for any changes to timing, work order, method, or resources from the program submitted at the time of tender, or if submitting an updated construction program, reasons for such changes from the previously submitted program.

The construction program submitted in accordance with the provisions of this clause shall in the opinion of the Engineer be reasonable in all respects. The Contractor's program, when approved, shall be known as the Contractual Program.

- b. Whenever the Contractor proposes to change the Contractual Program, he shall immediately advise the Engineer in writing and if the Engineer considers the change is a major one, the Contractor shall submit a revised program for approval. If such a change in the program affects the Engineer's design and the drawing approval program, the Employer will not be responsible for the consequences of the late issue of any drawings, which are attributable to that change.
- c. If the Contractor falls behind the revised Contractual Program he shall, within 14 days of the date of such default, submit for approval a revision of the program showing the proposed measures, including additional plant, labour and material resources, to complete the Permanent Works on time.
- d. When instructed, the Contractor shall promptly furnish a detailed sub-program of the Contractual Program for particular sections of the Permanent Works.

- e. The Contractor shall also attend weekly meetings with the Engineer and provide, not less than 2 days prior to each meeting as required by the Engineer, detailed programs showing separately the various activities of the Contractor anticipated over the forthcoming two week period as well as the progress achieved over the preceding week relative to the program applicable to that period.

5.2 Monthly Progress Report

Before the tenth day of each month, the Contractor shall submit three copies of a monthly progress report in a form acceptable to the Engineer detailing the progress during the preceding month. The monthly progress report shall show the amount of work completed, materials actually used, materials in storage and the cumulative results of all operations completed or in progress and shall be summarized in terms of percentage of completion referenced to the approved programme for the works.

The monthly progress report shall include at least the following:

- Total percentage of work completed and total percentage programmed to be completed by the end of the reporting period;
- Actual percentage of each main work items completed including temporary works, as well as their scheduled percentage, both total and for the reporting period together with the estimated quantities;
- List of manpower by trade and by position for the reporting period;
- List of equipment and operational days for the reporting period and materials on site at the end of the period;
- Description of weather conditions for the period including records of each rainfall duration and recorded water levels of the Tank;
- List of any accident except of minor nature and any damage that occurred;
- Any matter which affected or may affect the progress of the work, problems encountered and proposed remedial measures;
- Colour photographs with imprinted date, not smaller than 100 mm by 150 mm of the work progress during the period for all major components of the Works. The Contractor shall also provide digital versions as well as 5 sets of hard copies of these photographs in albums with titles.

6. Contractor's Equipment

The Contractor shall supply, install, operate, maintain and subsequently remove all Contractor's equipment required for the execution of the Works. In particular, the Contractor shall supply all those items listed on the Technical Proposal in the Contract at the time stated therein or at such other time as may be deemed necessary in the opinion of the Engineer.

The Contractor's equipment shall not be removed from the Site without the written approval of the Engineer. If during the execution of the Works any item of the Contractor's equipment in the opinion of the Engineer, is unsuitable so as to fail to perform the services required in the execution of the Works, the Contractor shall replace such construction equipment with another suitable one at his own cost.

The Engineer may, if he considers it necessary for the execution of the Works in accordance with the Contract, order the Contractor to supply additional items of Contractor's equipment or extend the period for which the Contractor's equipment is required. The Contractor shall supply and stock all essential spare parts for his equipment to ensure the efficient execution of the Works.

The Contractor shall submit a Monthly Equipment Report, which lists the following information about the Contractor's equipment.

- a. List of all equipment located at the Site
- b. Daily working and operation record of each item of equipment
- c. Inspection, repair and maintenance records
- d. Quality of work
- e. Quantities of fuel, lubricant, oil and tires consumed
- f. Overhauling record
- g. Accident report
- h. List of unserviceable equipment and action being taken to put back in operation

7. Standards

Except as otherwise specified in this Specification, all materials and workmanship shall comply in all respects with the requirements of the appropriate standard of code issued by the British Standards Institution, American Society of Testing and Materials, US Corps of Engineers, Technical Methods for Highways, or such other standard as the Engineer may approve, current at the date of Invitation to Tender. If, after the date of Invitation to Tender, there is an amendment to a standard relevant to the Contract, the Engineer will direct whether the amendment is to apply.

The Contractor shall have available in his site office at all times at least one copy of every standard or code referred to in this Specification, and any additional standard or code which may be referred to therein, and shall make these available for reference by the Engineer upon request.

8. Setting out Works

9.1 Existing Survey Date

The Tender drawings included in the bidding document are prepared based on the surveys carried-out by the Engineer during design stage.

9.2 Responsibility for Setting Out

The Contractor shall be solely responsible for the correct setting-out of the Works and shall employ experienced qualified surveyors acceptable to the Engineer for this purpose.

The Contractor shall furnish all materials, labour and equipment including stakes, templates, patterns, platforms and special labour that may be required by the Contractor in setting out any part of the Works. The Contractor shall give the Engineer not less than 24-hour notice of his intention to set out, survey or give levels for any part of the Works in order that arrangements can be made for checking the accuracy of the setting out, survey or levels. In order that the Engineer can expedite such checking the Contractor shall as soon as practical supply the Engineer with records in an approved form relating to all reference pegs and benchmarks in connection to the set out, survey or levels for any part of the Works which are required to be checked.

9.3 Contractor's Site Staff

The Contractor shall provide competent qualified survey technicians and the necessary support teams to carry-out all survey necessary to set out the Works in a neat and workmanlike manner.

9.4 Survey Operatives for the Engineer

The Contractor shall supply chainmen and labourers as required by the Engineer who are well experienced in such works. Chainmen shall be experienced in assisting Engineer in survey work.

It shall be the discretion of the Engineer to select chainmen and labourers whom he considers reliable and suitable and the Contractor shall maintain the continuity of this staff.

9.5 Permanent Survey Pillars

Using the existing temporary benchmarks shown on the Drawings the Contractor shall establish permanent survey pillars sufficient to define the control survey and as directed. The permanent survey pillars shall be linked to the national map grid and their coordinates shall be shown on the As-Built Drawings.

Establishment of these permanent survey pillars shall be undertaken before any of the existing survey point markers are destroyed by the Contractor's operations.

9.6 Detailed Survey

The Contractor shall perform all calculations, surveying and setting out necessary to establish the accurate location of the structures to be constructed.

The Contractor shall submit for the review of the Engineer the methods he intends to employ and the precision he will attain for the setting-out of the Works.

The Contractor shall, under guidance and in the presence of the Engineer, carry-out surveys and measurements for record and payment purposes in accordance with the Conditions of Contract.

In the Engineer's own surveying for checking the Contractor's survey results, the Contractor shall render the Engineer all necessary assistance and services for such check surveys.

9. Safety Precautions

10.1 General

The Contractor shall comply with any safety instruction given by the Engineer. The Contractor shall exercise every reasonable precaution to protect from injury any person or property. The Contractor shall erect and maintain all necessary temporary fencing, barricades, barriers, signs and lights and provide fire alarm, fire extinguishing and fire fighting services at strategic points on the Site. The Contractor shall provide adequate ventilation, lighting and safe working conditions for his workmen engaged in all aspects of the Works. The Contractor shall adopt and enforce such rules and regulations as may be necessary, desirable or proper, to safeguard the public, and all persons engaged in the work and its supervision. Safety measures shall include but shall not be limited to those safety measure mentioned in this Clause.

10.2 Safety Officer

The Contractor shall constantly employ, during the progress of the Works, an employee qualified in safety, and familiar with the type of work being performed, whose assignments shall include initiation of measures for the protection of health and the prevention of accidents and who shall see, by personal inspection, that all safety rules and regulations are enforced.

The Contractor shall hold regular scheduled safety meetings at least once each month with his engineers, supervisors and foreman and, when instructed, with the Engineer. The Contractor shall keep the Engineer advised as to when these meetings are to be held and shall provide the Engineer with a copy of the proposed agenda.

10.3 Temporary Fencing

If required the Contractor shall erect, maintain and remove suitable and approved temporary fencing to enclose such areas of the Permanent Works and areas of land occupied by the Contractor within the Site as may be necessary to implement his obligation under the Contract, in an approved manner. Safety fences shall be erected around electrical and mechanical equipment before that equipment is connected to any electrical supply.

Where any temporary fence has to be erected alongside a road, footpath, or other public thoroughfare, it shall be of the type required by and shall be erected to the satisfaction of the Government authority concerned.

10.4 Lighting

Safety measures shall include but shall not be limited to the following:

Without limiting the generality of Clause 4.8 of the Conditions of Contract, the Contractor shall provide sufficient lighting to ensure that, in all places where work is in progress;

10.5 Signs

The Contractor shall provide all necessary signs for the Works. These shall include, but not be limited to;

- Standard road signs
- Warning signs
- Danger signs
- Safety signs
- Control signs; and
- Direction signs

Wording on all signs shall be in the English, Tamil and Sinhalese languages. The size, colour, lettering and location of all signs will be subject to approval of the Engineer and international sign convention shall, where applicable, be followed.

The Contractor shall maintain all signs placed by himself as well as those placed by the Employer. If the Engineer considers that the system of signs provided by the Contractor is inadequate to ensure safety, or is unsatisfactory in other respects, the Contractor shall add to, amend, or otherwise change the system to the satisfaction of the Engineer.

10.6 Accident Reports

The Contractor shall promptly report to the Engineer in the form to be prescribed, all accidents involving death or serious injury to staff or workmen, and furnish monthly reports of all accidents to staff or workmen involving loss of time, giving such information as may be instructed by the Engineer.

10.7 First Aid Officer

The Contractor shall constantly employ for the duration of the Contract a First Aid Officer and shall provide first aid and ambulance facilities in accordance with the General Conditions of Contract.

10.8 Other Safety Measures

Safety instruction – the Contractor shall at his own cost supply and issue to his employees, those of his sub-contractors and the Engineer, printed booklets of pocket size, on the scale of one per person, in Sinhalese and Tamil and in other languages used by his employees at Site, instructions based on good practice. Within 60 days of the Engineer's written order to commence the Works, proof copies of the booklet shall be submitted to the Engineer for approval before printing and amendments shall be made to the booklet to his entire satisfaction. The Contractor shall issue the booklet immediately after printing as required by this Clause and ensure that all employees are fully conversant with the instructions. Safety instructions shall deal with all safety including;

- a. Protective clothing, headgear and footwear
- b. Use of lifting equipment
- c. Use of drilling equipment
- d. Use and storage explosives
- e. Earthmoving
- f. Formwork erection
- g. Concreting
- h. Structural steel work
- i. Compressed air
- j. Welding and painting
- k. Routine for accidents or fires; and
- l. Watchmen, warning notices and barriers

The Contractor shall allow for ten (10) booklets for the use of the Engineer.

10.9 Provision of Personal Protective Equipment (PPE)

No construction work shall be carried on the Site before appropriate Personal Protective Equipment (PPE) is available for the operations planned. The Contractor shall, within 28 days of the Commencement Date, prepare for the consent of the Engineer a schedule of Personal Protective Equipment (PPE) for free issue, including replacement, to all persons employed on the Works, including employees of the Engineer and Employer. Provision shall also be made for supplying PPE to site visitors.

The schedule shall address the need to provide such clothing and equipment suitable for the climatic conditions on the Site.

The Contractor shall immediately implement the issue of such PPE once he has obtained the Engineer's consent to the schedule. During the course of the Contract, he shall ensure that at no time do the stocks of PPE in his Site stores fall below the level consented to by the Engineer in that schedule. As proof of this, he shall submit to the Engineer each month during the Contract an inventory of PPE showing records of issue and demonstrating the levels of such PPE being retained in his Sites stores. Furthermore, all persons employed by his on the Works shall be made aware of the need to wear such clothing and to use such equipment, and to maintain the same in good working order.

The Engineer will monitor the effectiveness of the implementation of the use of the PPE during the course of the Works, and may certify the reduction of the value of some of all of the relevant Bill of Quantities items in the Monthly Statements in the event of non-usage of PPE on the Site.

Pursuant to Clause 6.9 of the Conditions of Contract the Contractor shall remove from the Works any person who fails to wear PPE, or to use equipment as intended, or who has otherwise failed to comply with the Site Safety Regulations, and any supervisor who fails to enforce those regulations. The Contractor shall make this a condition of employment of every employee engaged in construction work.

11 Temporary Works

11.1 General

The Contractor shall execute, erect, maintain and remove upon completion of the Works, all Temporary Works in accordance with the proposals submitted with the Tender or with such modifications as approved by the Engineer from time to time.

11.2 Approval of Temporary Works

The Contractor shall submit to the Engineer for approval drawings and full particulars of all Temporary Works which he intends to construct at least 30 days before he desire to commence constructing such works.

The submission to, or approval by, the Engineer of any such proposals by the Contractor shall not relieve the Contractor of any of his responsibility for the sufficiency of the Temporary Works for their intended purpose.

The Contractor shall also obtain any necessary approval from local statutory or other Government authorities before commencing construction. Such work shall not be started without prior approval.

11.3 Removal of Temporary Works

On completion of the Works, all Temporary Works constructed by the Contractor or handed-over to the Contractor by the Engineer, unless otherwise specified or instructed by the Engineer, shall be removed from the Site, as approved by the Engineer.

The Contractor shall make safe all areas affected by Temporary Works and reinstate natural drainage. The Contractor shall finish, reinstate, clean up and relinquish parts of the Site at the end of the Defects Liability Period or such earlier times as instructed by the Engineer.

Buildings and facilities removed from the Site will become the Contractor's property. Foundations of buildings and structures shall be broken up and removed from the Site.

12 Contractor's Offices, Camp and Facilities

12.1 General

The Contractor shall provide a main office and site offices for his staff. The main office shall be located in the vicinity of the dam site. Site offices may be mobile field offices so that, when work at one site is complete, the office may be moved to another site. The Engineer will allocate a portion of the Works area at the dam site where the Contractor shall provide and maintain such offices, stores, workshops, housing and adequately fenced store and delivery compounds as are necessary for the execution of the Works, including all necessary services for water supply, drainage, lighting, roads, paths, parking places, sewerage and garbage disposal.

12.2 Construction Camp

- a. The Contractor shall set up his camp as proposed in his Tender and approved in the Letter of Acceptance, for housing, camps and for other required facilities and amenities for his employees and for the employees of his sub-contractors.
- b. The Contractor shall be deemed to have inspected these sites and made his own evaluation as to their adequacy and suitability for the development of the required camp facilities.
- c. The Contractor shall appoint a Camp Manager who shall be responsible for the administration and maintenance, and for all matters relating to the allocation of space, discipline and use of buildings and facilities.
- d. All buildings shall at all times be open to inspection by the Engineer. Any instruction given by the Engineer for the proper cleaning, disinfection and general maintenance in a sanitary and hygienic condition of any building must be forthwith carried-out by the Contractor. Before any buildings are occupied the Contractor shall draw up a code of rules and regulations for their control which shall be approved by the Engineer.

12.3 Removal of Buildings and Facilities

- a. On the completion of the Works, all buildings and facilities provided by the Contractor in accordance with the provisions of this Clause shall be removed from the Site by the Contractor unless otherwise instructed by the Engineer.
- b. Foundations of all buildings and structures shall be broken up and removed from the site. All areas shall be restored and left in a clean and tidy condition to the satisfaction of the Engineer.

13 Inspections and Material Testing Laboratory

13.1 Inspections

The Contractor shall carry-out the inspections and tests stipulated in the respective sections of these Specifications in the presence of the Engineer or any person authorized by him.

No work shall be covered up or put out of view without the approval of the Engineer and the Contractor shall afford full opportunity for the Engineer to examine and measure any work which is about to be covered up or put out of view and to examine foundations before the Permanent Works is placed thereon.

The Contractor shall give due notice to the Engineer whenever any such work or foundation is or are ready or about to be ready for examination and the Engineer will without unreasonable delay, unless he considers it unnecessary and advises the Contractor accordingly examine and measure such work or examine such foundations.

Should it be impossible for the Engineer to witness such inspections and tests, the Contractor shall record the results of such inspections and tests using the form specified by the Engineer, and submit to the Engineer the report by attaching the record photographs of the said inspections and tests as the record and report. These records and reports shall be subject to the approval of the Engineer.

These records and reports shall be prepared and submitted to the Engineer for approval irrespective of whether or not the Engineer has witnessed such inspection and tests.

In the case where the Engineer has approved and qualified the results of such inspections and tests, the Contractor may proceed to the next stage of the Works.

The inspections and tests specified herein shall include the following:

- a. Inspection of volume of work executed
- b. Inspection and test of construction materials
- c. Inspection of excavation (including bed surface)
- d. Inspection of reinforcement bar assembly
- e. Inspection of formwork
- f. Inspection of the dimensions of the structures
- g. Inspection of disposal of excavated materials
- h. Identification test of quality of concrete at site (cast-in-place concrete)
- i. Inspection of backfilling
- j. Other tests and inspections the Engineer deems necessary
- k. Other tests and inspections required according to pertinent regulations, codes and standards

The following tests and inspections shall be executed in the presence of the Engineer;

- a. Witnessing at concrete placing
- b. Compression test of concrete
- c. Other tests and inspections the Engineer deems necessary

13.2 Material Testing Laboratory

The Contractor shall provide and maintain until completion of the Works a materials testing laboratory complete with furnishing, fixtures and equipment and carry-out all routine tests including preliminary tests for the concrete works as required by the Technical Specifications.

13.3 Equipment

The Contractor shall provide and maintain furnishings and equipment of approved manufacture to carry-out testing.

The laboratory shall at all times be provided with a sufficient stock of consumable equipment, to allow for usage, breakage and deterioration. In the event of any item of equipment becoming unserviceable through any cause the Contractor shall, if required to do so by the Engineer, order replacement to be air-freighted from the country of origin.

The Contractor shall supply all equipment, supplies and copies of the relevant standards for the laboratory necessary to perform the tests stipulated in the Technical Specifications. These tests shall include but not be limited to the following:

- a. In concrete – temperature, slump, density, flow, air content
- b. In aggregate – grading, water absorption, specific gravity, soundness, flakiness, elongation, friable practices.
- c. In soil – grading, specific gravity, density (loose and compacted), moisture content, hydrometer, plasticity

The Contractor shall also provide any additional equipment as may be required by the nature of work or by the Engineer.

13.4 Costs

The tests required by the Technical Specifications or by the Engineer will be carried out by the Contractor in the Material Testing Laboratory or in other Laboratories proposed by the Contractor and approved by the Engineer. The cost of such tests including the preparation and transportation of the samples shall be borne by the contractor if not stated otherwise.

13.5 Facilities for Engineer to Take Samples

The Contractor shall provide facilities for the Engineer to take samples for testing of any of the fill, concrete or other materials to be incorporated in the Works. Such samples may be taken before or after incorporation into the Works or at any stage during construction at the discretion of the Engineer.

14 Quality Assurance System

As per Clause 4.17 General Conditions of Contract, the Contractor shall institute a quality assurance system to demonstrate that the Works are being carried out in compliance with the requirements of the Contract. The Contractor shall within 28 days from the receipt of Letter of Acceptance, submit the quality assurance system he is proposing to adopt in the Contract.

The Contractor shall build the quality assurance system for all his activities from the commencement to completion of the Contract. The system shall include but not limited to the following.

- Contractors site management
- Topographic surveys and setting out
- Construction Drawings
- Safety measures adopted
- Environmental Management
- Traffic Management
- Maintenance of Roads
- Construction Methods adopted
- Quality Control
- Progress monitoring
- Monthly Bills
- Monthly Bills

The quality assurance system instituted by the Contractor is a requirement under the Contract and no payment will be made to the Contractor for this work.

15 Dealing with Water

15.1 General

Where it is required that construction shall proceed with flow of water in streams and/or issue of irrigation water to canals, it shall be necessary to isolate the site of the structure to be constructed from the flow of water by the construction of suitable cofferdams, canals, flumes, drains, swamps and/or other temporary diversion and protective works without interruption or interference with the flow of water in the streams and/or issue in the canal. The contractor shall construct sufficient temporary works as described above to deal adequately with surface and ground water sources to enable the construction of the permanent works to the satisfaction of the Engineer.

The Contractor shall submit for the approval of the Engineer the location, size and other relevant details including the materials proposed for the construction of the temporary works described above. The contractor shall protect the works during the entire construction period from damage due to rains, surface run-off, floods, etc. and from failure of the temporary protective works constructed by him. Any damage to the works or delay to his operations from such events, whether due to his failure to adequately take such factors into consideration or not shall be corrected by the contractor, and will not constitute a basis for claims for additional payment or extension of time. The Contractor shall furnish, maintain and operate all necessary pumps and other equipment for removal of water from the various parts of the works free from water as required for construction. After having served their purpose, all temporary protective works, unless otherwise directed, shall be removed or levelled to give a sightly appearance, so as not to interfere with the operation of the other related works.

Unless specifically provided for in the Bill of Quantities, no separate payment will be made for dealing with water. The cost of all operations required for dealing with water shall be included in the respective items of works for which dealing with water is required.

15.2 Approval of Proposals for Dealing with Water

Prior to commencement of any works, the Contractor shall submit a Plan for Dealing with Water with full details of the construction, operation, maintenance and removal of the temporary protective works.

15.3 Removal of Water from Foundations

The Contractor's method of removal of water from foundation excavations shall be subject to the approval of the Engineer. Where the excavation for foundations extends below the water table in common material, the portion below the water table shall be de-watered in advance of excavation. The de-watering shall be accomplished in a manner that will maintain the stability of the excavated slopes and the bottom of the excavation, and will result in all construction operations being performed in the dry.

The Contractor shall be required to ensure that the bottom of the excavation is free of water prior to placement of concrete or fill material. Such control may required supplementing approved de-watering methods by the use of perforated pipe under-drains leading to sumps from which the water shall be pumped. The pipe drains shall be of uniform diameter for each run and provided with grout connections and returns at about 15 meter intervals and shall be embedded in reasonable well graded gravel or similar filter material.

During the placing and compacting of fill material in an excavated cut off trench, the water level at every point in the cut off trench shall be maintained below the bottom of the cut off trench until the compacted fill in the cut off trench at the point has reached a height of 3 metres. Therefore the water level shall be maintained at 1.5 metres below the top of the compaction fill. When the fill has reached an elevation which will permit the de-watering systems to maintain the water level at or below the designated elevations as determined to the Engineer, the pipe drains, if any, and surrounding filter material shall be filled with approved grout composed of water and cement or clay.

16 Tests for Borrow Areas and Quarries

16.1 General

All borrow areas and quarries where materials are to be used for permanent construction works shall be subjected to approval of the Engineer. The Engineer may cause any or all of the under-mentioned tests to be done in the Contractor's Field Laboratory at site and/or in the Employers Laboratory of the Irrigation Department.

16.2 Tests on Soils

From areas approved out for exploitation the following tests shall be conducted on a sample from the quantum that would be required for exploitation from such areas for placement in different parts of the embankment regularly as determined by the Engineer.

- (i) In-situ Moisture Content
- (ii) Atterberg Limits
- (iii) Mechanical Analysis, and
- (iv) Proctor Compaction.

The particle size grading for the fill materials are generally specified by limiting the range of the grading results obtained for each sieve. Material outside the limits, will be accepted or rejected at the Engineer's discretion according to the location on the embankment where the material is to be placed, volume required and the nature of the circumstances for the use of such material.

The tabulation below is a guide for the selection of materials for an embankment.

Table 16.2.1 - Grading and Plasticity Limits for Earth Embankments

Zone	Characteristics	Absolute Minimum (%)	Absolute Maximum (%)
Low Permeability	Passing 75 micron sieve	30	70
	Liquid Limit	20	50
	Plasticity Index	8	30
Medium or High Permeability	Passing 75 micron sieve	-	70
	0.355 mm sieve	8	-
	2.36 mm sieve	50	-
	25.0 mm sieve	100	100
	Liquid Limit	0	50
	Plasticity Index	0	30

16.3 Tests on Gravel

Materials from approved gravel quarries shall be tested periodically for the following characteristics:

- (i) Mechanical Analysis, and
- (ii) Atterberg Limits.

16.4 Tests on Sand

Materials from approved sand quarries shall be tested periodically for the following characteristics:

- (i) Gradation
- (ii) Specific Gravity, and
- (iii) Organic Content

16.5 Tests on Rock

Rock samples from approved quarries shall be tested periodically for the following characteristics:

- (i) Gradation
- (ii) Specific Gravity
- (iii) Los Angeles Abrasion Test, and
- (iv) Sodium or Magnesium Sulphate Soundness Test

17 Embankment Filling

17.1 General

The embankment shall be constructed to the dimensions shown on the drawings with approved materials obtained from designated borrow areas and approved excavations. The distributing and gradation of the material throughout the embankment shall be of such homogeneous texture such that the fill will be free from lenses, pockets, streaks or layers of material differing substantially in gradation from the surrounding material. Relatively higher plastic material available from borrow areas shall be used in the central portion and previous material from approved excavations on the downstream slope of the embankment respectively.

The Engineer will give guidance in the selection of material for placement in different parts of the embankment on the basis of investigations done and/or tests carried out. Materials used in the embankment fill shall be continuously subject to the approval of the Engineer.

The combined excavation and placing operations shall be such that the material when compacted in the fill will be blended sufficiently to obtain the required degree of compaction. Successive loads of material shall be placed in layers so as to produce the best practicable distribution of the material subject to the approval of the Engineer for which purpose he may designate the locations in the fill where the individual loads shall be deposited.

Cobbles and rock fragments in material of homogeneous texture, of dimension larger than 75 mm shall not be placed in the fill. Such cobbles and rock fragments found in otherwise approved fill material shall be removed by the Contractor either at the site of excavation or after being transported to fill but before the materials are placed and compacted and shall be disposed as directed by the Engineer.

17.2 Placement

Embankment material shall be placed in continuous rows/lanes approximately parallel to the axis of the embankment and in approximately horizontal layers of thickness between 200 and 300 mm before compaction by machinery. If hand tools are used for compaction the thickness of layer shall be between 100 to 150 mm. the embankment may be constructed in separate reaches provided that the slopes of the bonding surfaces parallel to the dam axis between the completed portion of the embankment and material to be newly placed shall not be steeper than 6 horizontal to 1 vertical. The difference in elevation during construction between any adjacent lanes shall not exceed 500 mm.

17.3 Moisture Content

From a practical standpoint a moisture range of 1% less than the optimum and 1% more than the optimum may be regarded as satisfactory during compaction. Water required for conditioning the fill may be conveyed by pipeline or bowser and applied by sprinkler arrangement and throttle to control quantity. Jets may be used in confined areas provided that the nozzle is of an approved size and delivery rate.

The required water may added to the previously rolled layer before placing of the material for the next layer, or added to the top of the next layer, or a combination of both which will give the best results for

obtaining a uniform moisture distribution throughout the layer. Harrowing will be required to work the moisture into the layer. Water may be added to the borrow areas by any of the methods described above on the day prior to exploitation, particularly where the ground is too hard and dry. This shall not preclude the addition of a further quantity of water to meet any deficiency in the placement moisture content just before spreading and compaction on the embankment. The methods described above adopted by the Contractor shall be subject to the approval of the Engineer.

If the moisture content of the previously rolled embankment or the material placed for compaction on fill is found to be above the specified limit before compaction then the material shall be dried out to the specified moisture content limit assisted by discing and/or harrowing. In such instances all hauling and other equipment except those required for discing or harrowing shall be kept off the surface to prevent rutting.

In case of stoppage in placing and compacting arising from approved construction or from holiday period exceeding one week or from unforeseen circumstances etc., the top layer placed and compacted before the stoppage shall be graded and rolled with a smooth wheel roller to facilitate surface run-off during the stoppage. Prior to resumption of work the top layer shall be scarified and moistened or allowed to dry as found necessary and approval of the Engineer obtained for continuing the operations.

17.4 Compaction

When each layer has been conditioned to 100% +/- 1% of the optimum moisture content, it shall be compacted by a towed tamping roller, self-propelled vibratory roller, pneumatic tire roller or any other suitable compacting equipment. Compaction with sheep-foot rollers shall be continued until the dry unit weight of the compacted material is not less than 98% of the standard "A" Proctor dry unit weight, which is the dry unit weight at optimum moisture content. The number of passes of the compacting equipment required to produce the above unit weight shall be determined from trial embankment tests conducted by the Contractor and witnessed by the Engineer. The layer shall be compacted in a direction parallel to the dam axis. The compacting equipment shall travel with adequate overlap to ensure thorough and complete compaction.

The embankment shall be brought up in approximately horizontal lifts. Proper compaction shall be ensured throughout the entire embankment. The outer edges of the embankment shall be processed to true slopes which shall be maintained until final completion and acceptance. To ensure proper compaction of true slope the other edges shall be made sufficiently wide and trimmed to true slopes.

17.5 Tests for Embankment

When an area of the embankment has been rolled, the bulk unit weight, moisture content and dry unit weight shall be obtained from the following conditions:

- (i) For every 750 cubic metres of material placed in each layer,
- (ii) Where embankment operations are concentrated, namely when two or more layers are placed over each other on the same day the frequency of tests shall be more than (i) above as determined by the Engineer,
- (iii) At every location where the degree of compaction is considered doubtful by the engineer,
- (iv) At locations of embedded installations at the discretion of the Engineer.

Compacted samples from every 7,500 cu metres shall be tested for the following.

- (i) Atterberg Limits,
- (ii) Mechanical Analysis, and
- (iii) Proctor Compaction

18 ENVIRONMENT AND SOCIAL MANAGEMENT PLAN (ESMP)

The Contractor shall comply with the provisions in the **Environment and Social Management Plan (ESMP)** annexed in this section without any cost to Employer. Provisions on BOQ Sub Item 1.4.9 and ESMP will be provided in signing contract

18.1 Environmental Control

The Contractor shall: -

- Comply with the provisions of this Section and other environmental protection provisions in the Contract and with the requirements of any statute, by-law, standard and the like related to environmental protection.
- Arrange all work to cause the least possible disturbance to the environment.
- Submit proposals for traffic movement, temporary structures, cleaning up, storage of materials, demolition and the like. Observe the agreed proposals.
- Dispose of all spoil and unsuitable material in accordance with the provisions given in EMP.

18.2 Monitoring

The Contractor shall monitor the environmental aspects of the construction and the control measures implemented to minimize any adverse environmental impact. Should the control measures put in place be found to be unsatisfactory as a result of the monitoring then the Contractor shall amend the control measures to provide a satisfactory result.

18.3 Environmental Complaints

The Contractor shall maintain a register of all environmental complaints received and shall notify the Engineer of each complaint. Complaints received by the Engineer and referred to the Contractor shall also be recorded in the register.

The Contractor shall investigate all environmental complaints received and where necessary, undertake measures to address the complaint. All measures undertaken to address complaints shall be detailed in the register.

18.4 Environmental Incidents

Should an environmental incident (being environmental nuisance, medium environmental harm, or serious environmental harm) occur during any construction phase, the Contractor shall immediately take the appropriate action to minimize any impact and inform the Engineer. The Contractor shall carry out any instructions received from the Engineer.

The Contractor shall be responsible for the cleanup of any contamination caused by the construction works and no additional payment will be made in this regard.

18.5 Environmental Training

The Contractor shall be responsible for ensuring that all employees (including subcontractors) have received training in relation to the Contractor's environmental operating guidelines.

The Contractor shall ensure that any machinery on site is operated within the appropriate guidelines so as to minimize environmental impact in relation to noise, air and water quality, waste control and contamination. All construction materials used on site shall be utilised in a manner to similarly limit environmental impact.

No additional payment shall be paid to the Contractor and the cost of environmental control measures shall be deemed to have been included in the rates tendered for the Works.

19 Standard Procedure for Ensuring Occupational Health and Safety When working in Wildlife Area

The Contractor shall comply with the provisions in the Standard Procedure for Ensuring **Occupational Health and Safety When working in Wildlife Area** annexed in this section without any cost to Employer.

20 Standard Procedure for Assessing the Requirement of Tree Removals

The Contractor shall comply with the provisions in the **Standard Procedure for Assessing the Requirement of Tree Removals** annexed in this section without any cost to Employer. Also, contract has to take the approval from proper Authority before removing the tree. All the removed trees should be destroyed or Store at Chadayanthalawa unit office based on the instruction given by the Engineer to Contract.

21 Labor Management Plan (Including site management and camp management measures)

The Contractor shall comply with the provisions in the **Labor Management Plan (Including site management and camp management measures)** annexed in this section without any cost to Employer.

Reference



Integrated Watershed and Water Resources Management Project (IWWRMP)

Standard Procedure for Ensuring Occupational Health and Safety When working in Wildlife Area



Content

1. Purpose
2. Common hazards may occur when working in Wildlife areas
3. Planning for Occupational Health and Safety (OHS).
4. Safe Operating Procedure
 - 4.1 General procedures
 - 4.2 Common preparedness
5. Common actions to be followed
6. Precautional actions
 - 6.1 Precautions against bees/wasp stings/bites
 - 6.2 Precautions against large mammals
 - 6.3 Precautions against snake bites
 - 6.4 Precautions against crocodiles' attacks
7. General conditions of workers
- 8. Personal Protective Equipment needed**

1. Purpose

Workers who are working in wildlife or forest areas can be exposed to wildlife threats. Therefore, persons working in these areas need to strictly follow the guidelines and regulations given by the relevant authority. To fulfill this requirement, contractors and workers will have to follow the occupational health and safety guideline covered in this document during their working period in the wildlife/ forest areas.

2. Common hazards that may occur when working in Wildlife areas

1. Infectious diseases transmission from mosquito or small animal bites.
2. Swelling, mild or severe allergic reactions from stinging insects.
3. Swelling, mild or severe allergic reactions or death from snake bites.
4. Serious injury or death from contact with large mammals or reptiles.

3. Planning for Occupational Health and Safety (OHS).

1. Review identified area, its nature, jurisdiction, conservation status and relevant authority.
2. Plan to get relevant authorization and get clear idea about given conditions and required OHS measures.
3. Purchasing of relevant safety equipment. (Example – Personal Protective Equipment)
4. Provide necessary trainings to staff. (Example – First Aid, emergency protocols)
5. Appoint a person to supervise OHS.

4. Safe Operating Procedure

4.1 General procedures

- 4.1.1 Obtain conditional approval from authorized agency (Example – Department of Wildlife Conservation / Forest Department).
- 4.1.2 Understand the given conditions and take action to aware all workers (including drivers and supporting staff) on the given conditions.
- 4.1.3 Obtain the service of 01 or 02 officers from relevant authorized agency and always accompany them to relevant sites and work under their supervision and guidance.
- 4.1.4 If any risks or danger is anticipated, felt or identified in the area of work, immediately take action to inform authorized persons and get their direction.

4.2 Common preparedness

- 4.2.1 Be aware of working area and current conditions and history. (Example –elephant attacks / crocodile attacks)
- 4.2.2 Always carry a mobile phone or some communication system. (In some protected areas of Sri Lanka, there is no mobile phone coverage).
- 4.2.3 Select suitable vehicles, at least two vehicles should be mobilized (good condition, 4-wheel, toolbox, tire ropes and winch, etc.). Persons will not engage in any activities alone.
- 4.2.4 Always bring a first aid box/ stretcher.
- 4.2.5 Be aware of nearest hospital and nearest route.
- 4.2.6 Be equipped with enough clean drinking water for workers.

5. Common protocol to follow

1. Be aware of your surroundings, and note any wild or suspicious acting animals in your working area.
2. Identify and be aware about wild animal active times and try to avoid those times.
3. Avoid reaching or stepping into or over hidden areas that may contain wildlife.
4. Be aware of signs that indicate above or below ground animal nests. Also take appropriate action to prevent contaminations of these areas.
5. Avoid direct contact with birds, bats, or other animal droppings.
6. Avoid direct contact with animal blood. If contact cannot be prevented, wear rubber gloves and dispose properly.
7. Do not feed any wild animal.
8. Do not capture / harm wild life or plant species and do not collect anything from protected area. (Example fallen animal horns, bones, tusks (ivory), etc).
9. Set fire under (if necessary) should do under supervision of wildlife officers and after use take action to completely extinguish it.
10. Allocate one person to be on guard/vigilance while other workers are at work

6. Precautional actions

6.1 Precautions against bees/wasp stings/bites

- 6.1.1 Awareness about working areas and presence of bee hives or wasp nests.
- 6.1.2 Do not wear perfumes, colognes, scented soaps or powders.
- 6.1.3 Tuck pants into your socks or working boots.
- 6.1.4 Wear safety hats with face protecting net.
- 6.1.5 Do not make more noise than necessary when working.
- 6.1.6 Establish safety cage with enough space. (If possible)
- 6.1.7 Provide safety kit for workers
- 6.1.8 If you decided to remove bee/ wasp nest from working site, the authorized agency (example Department of Wildlife Conservation -DWLC) should be informed and their concurrence and assistance should be sought prior to implementation.
- 6.1.9 Always consult and take a service from qualified pest-removal expert. (Example – Bee conservation Society of Sri Lanka)

6.2 Precautions against large mammal attacks

- 6.2.1 Be aware of working site, access routes etc.
- 6.2.2 Be aware on animal movement routes, times, nature of the animals etc.
- 6.2.3 Try to avoid contact with wild animals. (Example – use an alternative route)
- 6.2.4 Request wildlife officers to bring/provide safety equipment (Example - Thunder-flashes).

6.3 Precautions for prevention of snake bites

- 6.3.1 Be vigilant and aware of working area.
- 6.3.2 Always wear safety boots.
- 6.3.3 Do not put hands or legs into hidden holes, anthills or any hidden spots.
- 6.3.4 Do not touch dead or live snakes.

6.4 Precautions for prevention of crocodile attacks

- 6.4.1 Be vigilant and aware of working area on crocodile signs (Example – foot prints, scats, hiding holes etc) and if those signs are available immediately inform to authorized officials and get their advises.
- 6.4.2 Do not put your hands or legs in to crocodile hiding holes / do not enter into crocodile hiding holes.
- 6.4.3 Do not enter into unsafe water.
- 6.4.4 If you need to work in open waters, establish protective cages.
- 6.4.5 Observe the working area thoroughly before entering in to open waters or protective cages.

7. General Conditions of workers

1. Workers should be in good health condition.
2. Should agree to follow given conditions and safety measures given from time to time and unexpected conditions.
3. Do not consume alcohol while working.
4. Always pay attention to surroundings.
5. Always stay as a group.
6. Do not litter.
7. Aware of all Do's and Don'ts. (contractor and supervision officers are responsible for this).
8. Establish temporary signboards on Do's and Don'ts at working sites.

8. Personal Protective Equipment need to used

1. Insect repellent
2. Long-sleeved shirts and pants (Jungle green/ dark color)
3. Safety boots
4. Insect spray designed for bees/wasps/hornets
5. Safety hats with face protector (specially protect from bees and wasps)
6. Life jackets/ raincoats.
7. Life-saving equipment for working in water.
8. Re-chargeable torches / lighting equipment.



Integrated Watershed and Water Resources Management Project (IWWRMP)

Ministry of Irrigation

Labor Management Plan

(Including site management and camp
management measures)



2026

Abbreviations

IA	-	Implementing Agency
IWWRMP	-	Integrated Watershed and Water Resources Management Project
LMP	-	Labor Management Plan
PMU	-	Project Management Unit
PHI	-	Public Health Inspector

Introduction

Labor management plan of the Integrated Watershed and Water Resources Management Project (IWWRMP) provides basic guidance to contractors to smoothly function of project activities without basic issues. Selected contractors shall follow this plan simultaneously with other relevant laws and regulations. The prepared labor management plan consists with site management measures and camp management measures with outlining a range of mitigation measures designing to avoid or reduce undesired labor management, site management and camp management impacts during construction.

The plan has been prepared by structuring relevant major subject areas that need to pay attention and provides identified mitigation measures with responsibility and frequency of monitoring.

Objectives of the plan

The objectives of the labor management Plan are:

- Avoid or reduce negative impacts on environment due to establishment of project sites.
- Establish standards on worker welfare and living conditions at the camps that provide a healthy, safe and comfortable environment.
- Avoid or reduce negative impact on community and maintain constructive relationships between local communities and workers' camps.

Roles and responsibilities

- Contractor shall ensure sufficient resources are allocated on an ongoing basis to meet the requirements of this Plan.
- Contractor shall strictly adhere to other necessary acts, rules and regulations related to the labor management and obtain necessary approvals.
- The Contractor shall pay attention to implement labor management plan monitor the progress.
- Contractor shall facilitate to PMU or IA to monitor the progress of LMP.
- Contractor shall comply to make necessary amendments to the LMP after the site inspections of PMU, IA or authorized entity.
- Contractor shall comply to provide necessary awareness and trainings to labors about rules and regulations, guidelines and general information time to time.

No	Major field	Sub field	Mitigation and management measures	Responsibility	Monitoring frequency
1	Plan basic arrangements of worksite management	Site identification and demarcation	Contractor should identify the exact area of work site before start project activities.	Site engineer & Contractor	-
			Contractor should plan the work site to identify appropriate places for site office, labor camps, yards, stores, parking areas etc.	Site engineer & Contractor	-
			Contractor should obtain relevant approvals form IA and site engineer.	Contactar	-
			Fence or protective measure should be placed around the work site.	Contactar	-
		Control public access to work site	All public access to the work site should be prohibited or controlled to avoid risk to the public.	Contactar	Monthly
			Signboards should be displayed at all entry points which indicating "Authorized entries only" or "prohibited to public entrance".	Contactar	Monthly
			Contractor shall take action to establish a temporary security point at the entrance and assigned a person to duty for 24 hrs. for security of the site and monitor vehicle and monitoring transfer of goods into and out of camps.	Contactar	Weekly
			A register shall be maintained at the security point to register all labors/ officers/vehicles which enter / departure to/from the work site.	Contactar	Weekly
		Disclose of basic information to workers and interest groups	Contractor should established signboards at the main entry point to display detailed information of the proposed project.	Contactar	Monthly
			Safety signs should be displayed at the entrance and other necessary places at the work site.	Contactar	Monthly
			Contractor should established a notice boards at the work site and necessary information should be displayed in time to time.	Contactar	Monthly
			Contractor should establish a notice board on COVID 19 health guideline at the entrance.	Contactar	Monthly

No	Major field	Sub field	Mitigation and management measures	Responsibility	Monitoring frequency
		Establishment of site office	Contractor should established a site office according to the site plan and should maintain appropriate working condition.	Contractor/ Site engineer	-
			Necessary documents (guidelines, ESMP, copy of approvals etc.) should be placed at the site office.	Contactora	Monthly
			First aid box with essential drugs should be placed at the site office.	Contactora	weekly
			Fire protection equipment should be placed at the site office.	Contactora	Monthly
			Contractor should maintain an extra stock of safety equipment at site office to issue when necessary.	Contactora	Monthly
			Hazards, explosives or any harmful chemicals should not stock in the site office .	Contactora	weekly
2	Plan work site arrangement	Readiness for emergency response	Contractor shall develop an emergency response plan that meets requirements of emergency situation.	Contractor	-
		Ensure the safety of workers	Contractor should be placed temporary fences/ barricade tapes or protective measures to identify working areas, heavy machinery operating areas and areas where having deep excavations and activities of hazardous nature for the workers.	Contractor	Every 2 weeks
			Specific area in the site should be reserved to store construction materials.	Contractor	Monthly
			Specific area /place/ rooms should be reserved for store Hazards, explosives or harmful materials or chemicals.	Contractor	Weekly
			Materials should stock piled without exceeding approved height.	Contractor	Monthly
			Areas should be demarcated to park vehicles/ heavy machines or vehicle repairing and relevant sign boards should be displaced.	Contractor	Monthly
			Fire protection equipment should be established in the work site at most essential places.	Contractor	Every 2 weeks
			The contactor shall take action to strictly follow the COVID 19 operational guideline declared by the Ministry of Health at work site.	Contractor	Once a week

No	Major field	Sub field	Mitigation and management measures	Responsibility	Monitoring frequency
			Workshops, Stores, should establish according to the approved site plan.	Contacto	-
			Equipment (including power tools) should store properly, listed and assigned a person to issuing and receiving.	Contractor	Weekly
3	Establishment of Pollution Control measures	Control of Dust and emission,	Stock piled materials should be covered with appropriate cover or sprinkling water to control dust emission.	Contractor / Site engineer	Daily
			Dust emission form earth works (when operating) should controlled by sprinkling water.	Contractor / Site engineer	Daily
			Contractor should take action to transport excavated debris to approved dumping sites and should not store at work site.	Contractor / Site engineer	Daily
		Control of noise and vibration	Contractor shall adhere to strictly follow given condition for noise limits and vibration limits. (far day and night)	Contractor / Site engineer	Daily
		Control of water pollution	Silt traps should be established in relevant places.	Contractor / Site engineer	Monthly
			Proper solid waste management mechanism should be established in the work site.	Contractor / Site engineer	Daily
			Precautions should be established to avoid oil, fuel or lubricant contamination.	Contractor / Site engineer	Daily
		Final clearance and restoration of worksite	After the completion of project activities contractor shall carefully remove all temporary buildings, huts, stocked piled materials, temporary blocks of streams etc. form the work site and follow up the approved site restoration actions.	Contractor / Site engineer/PMU	-
4	Labor management measures	Adhere to lows and regulations	No labor under the age of 18 will be hired for work under this contract.	Contractor	Daily
			Contractor shall strictly follow relevance lows and acts related to labor management.	Contractor	-
		Contractor shall obtain necessary approval when increased the number of workers in labor camps	Contractor	-	
		Contractor shall maintain a log of any grievances/complains and actions taken to resolve them.	Contractor	Weekly	

No	Major field	Sub field	Mitigation and management measures	Responsibility	Monitoring frequency
			Workers shall abide by camp rules which includes a disciplinary process.	Contractor	Daily
			Contractor shall limit workers interaction with community when outside the camp.	Contractor	Daily
			Contractor's personnel shall not engage in any discrimination or harassing behavior.	Contractor	Daily
		Arrangement for conduct basic awareness for workers	Contractor shall take action to develop a labor code of conduct and translated it in to local languages upon clearance from the Engineer. The code of conduct must be made available to all staff and displayed in the work site in local languages.	Contractor	Monthly
			Contractor shall give necessary advices and instructions to all labors and drivers of the site to follow code of conducts.	Contractor/Site engineer/IA/PMU	When necessary
			Contractor shall take action to conduct labor awareness programs to educate the laborers about the code of conduct, general conduct, the Environmental and Social Management Plan, Occupational Health and Safety etc.	Contractor/Site engineer/IA/PMU	When necessary
		Labor safety and welfare facilities	Contractor shall provide sufficient safety gears to labors and need to monitor the utilization.	Contractor/ Site engineer	Daily
			Contractor shall take action to follow safety measures specially in handling of explosives, hazard chemicals, electricity etc.	Contractor/ Site engineer	Daily
			Contractor shall provide equal facilities / standards for all labor camps in the site and do not make any differences on worker's race, gender or nationality.	Contractor/ Site engineer	Daily
			Contractor, as appropriate, shall provide adequate recreation facilities for workers to reduce incentive for leaving camps during leisure time.	Contractor/ Site engineer	Monthly
			Contractor shall pay more attention and provide better quality safety equipment to the workers who are engaging with danger/ risk activities.	Contractor	Daily
		Recognition of cultural, nationality, religion rights.	Contractor may provide prayer rooms and other facilities, as necessary and to the extent practicable, to satisfy the religious needs and customs of its workforce. (if necessary)	Contractor	Monthly

No	Major field	Sub field	Mitigation and management measures	Responsibility	Monitoring frequency
5	Labor Camp management	Planning of Labor camps	Labor camps shall be established according to the approved site plan.	Contractor/ Site engineer	-
		Address community grievances	PMU or IA may request that camp related activities/operations be amended to address community grievances. Contractor shall comply with these requests.	Contractor	-
			Establishment of labor camps shall be commenced only upon the written approval of the Engineer.	contractor	-
			IA/ PMU may request that camp related activities/operations be amended to address community grievances. Contractor shall comply with these requests.	Contractor	-
		Maintain health condition	Contractor shall comply with the minimum health requirements for project execution and the community Health and Safety Management Plan which set out requirements and management measures on controlling communicable diseases within camps and to outside communities.	Contractor	Daily
			Contractor shall routinely monitor the quality and supply of water and other health related facilities.	contractor	Monthly
		Maintain Living and hygienic conditions	Contractor shall be maintained necessary living accommodation and ancillary facilities in functional and hygienic manner and as approved by the Engineer.	Contractor	Monthly
			Contractor should provide separate resting and sanitary facilities for both men and women laborers.	Contractor	Monthly
			All temporary accommodation should be established and maintained in such a fashion that uncontaminated water is available for drinking, cooking and washing.	Contractor	Monthly
			Washrooms should have sufficient and proper water supply.	Contractor	Weekly
			Drinking water facility should be provided to labor camps.	Contractor	Daily
			COVID-19 health guideline shall be applied at the labor camps and throughout the work site.	Contractor	Daily

No	Major field	Sub field	Mitigation and management measures	Responsibility	Monitoring frequency
		Application of Waste management measures	The sewage system for the camp, if not available, shall be planned & implemented with concurrence from the Local Public Health Officer (PHI).	Contractor/ Site engineer	-
			Proper solid waste management system (waste collection method/ separation method and final disposal method) should be established at labor camps.	Contractor	Weekly
			Waste water (from kitchen, washrooms, canteen etc.) should not released into open water bodies or streams.	Contractor	Weekly
		Final clearance and camp demolishing	After the completion of project activities contractor shall carefully remove all temporary buildings, huts, labor camps, toilets form the work site. Temporary toilet pits should treat and demolish accordance to approved health guidelines. Approved site restoration actions should implement.	Contractor/IA/ PMU	-



Integrated Watershed and Water Resources Management Project (IWWRMP)

Standard Procedure for Assessing the Requirement of Tree Removals



2026

Standard Procedure for Assessing the Requirement of Tree Removals

1. Planning Stage

- 1.1 Consultancy teams should be appraised by the PMU to pay attention and document the requirement of tree removals at each site.
- 1.2 Consultancy team should discuss with officials of relevant implementing agency on proposed tree removals to identify exact requirement and alternatives explored.
- 1.3 Ground verification on tree removals should be done by team of IA and PMU. Officials from implementing agency and representatives from community organizations shall also participate and records with attendance list be taken. All trees identified for removal should be measured for their Diameter at Breast Height (DBH).
- 1.4 Special attention shall be given if any of the selected trees are considered rare, endemic, religiously, historically or culturally important, or are in roosting/ nesting sites etc. The removal of these trees should be avoided and alternatives sought. Unavoidable removals shall be supported with sufficient justification.
- 1.5 Proposed unavoidable tree removal identified and confirmed at ground verification should be declared and requirement explained to the public at community consultative meetings. The removal should be comprehensive justified with scientific/ engineering support. Sufficient time for community public feedback shall be provided. All suggestions provided shall be given due consideration.
- 1.6 If public raise key concerns/questions/ protests/ alternatives, the proposed list of tree removal shall be revisited with the relevant implement agency.
- 1.7 Include finalized tree list in to draft ESMP (scientific justification need for each tree which has identified to be removed). All mitigations and compensatory tree planting activities shall be presented explicitly in the ESMP.
- 1.8 Submit draft ESMP to PMU with all required information and photos on proposed tree removals.

2. Reviewing Stage

- 2.1 ESMPs shall be reviewed by PMU and further discussion with consultancy team will be conducted if necessary.

- 2.2 Field visit will be conducted by the PMU further verify of the requirement of proposed tree removals with officials of relevant implementing agency and representatives of community organizations.
- 2.3 The proposed tree removal list in the ESMP will be revisited post field visit and any necessary amendments will be made if necessary in concurrence with the implementing agency.
- 2.4 The final stage shall be to obtain the recommendations of DSRP (SPELL OUT) on tree removals and further amend list according to the recommendations of DSRP

3. Obtaining Clearance / approvals (responsibility of Implement Agency)

- 3.1 The finalized tree removal list shall be shared with relevant approving officers/ agencies like Grama Niladhari, Divisional Secretariat, District Secretariat, Forest Department, State Timber Corporation, Central Environment Authority/ Provincial Environmental Authority etc. The obtaining of the clearances, where required, will be the responsibility of the implementing agency will be done prior to any removal of trees.
- 3.2 All clearances shall be shared with the PMU and endorsed before the tree removal activities are commenced. If any conflicts arise, the PMU will bring it to the notice of the World Bank E&S team immediately.

4. Awareness program (Implementation Agency / PMU)

- 4.1 Awareness programs for selected contractors shall be conducted on environmental and social impact mitigation measures with special attention on tree protection/removal guidelines.
- 4.2 Contractors shall be strictly advised not to remove trees unless essential. They shall be instructed to follow the ESMP strictly and any deviations shall be notified to the implementing agency and the PMU in advance for necessary action.
- 4.3 The removal of trees will be presented at the project introductory meeting and any other community level meetings.
- 4.4 Continuous field inspection and monitoring shall be conducted with a more concerted focus during land preparation and tree removal period.
- 4.5 Public complaints shall be attended to without delay adopting the protocols in place for GRM

5. Ecosystem restoration (Contractor)

5.1 Contractor shall carry out recommendations provided in the ESMP on remedial mitigation involving planting and maintenance of suitable tree species (as identified in the ESMP).

6. Monitoring and Evaluation (PMU/ Implementing agency)

6.1 Field inspection and monitoring will be carried out at regular intervals by the implementing agency and the PMU. Photographic evidence will be recorded for all tree removal activities.

6.2 Upon completion of required tree removal activities, site shall be evaluated to ensure that no further destruction has occurred. If satisfied, final clearance to proceed will be granted by the PMU.

6.2 If not satisfied, the contractor will be directed to utilize retention fund to carry out ecosystem restoration to the satisfaction of the implementing agency and the PMU. The WB E&S team shall also be notified under such circumstances.

Integrated Watershed and Water Resources Management Project (IWWRMP)

Checklist for Tree Removals.

Name of the Site

Date

No	Item/ Activity	YES	NO	Remarks										
1	Tree removal has been identified in ESMP													
2	List of tree removals with justification has been included in to ESMP (approved by WB													
3	Ground verification done by PMU													
4	Ground verification done by DSRP													
5	According to no 3 &4, Amendments included in to final tree removal list													
6	Conduct final community consultancy and briefing on tree removals by IA/PMU													
7	According to no 6, Any disagree / not at													
8	If disagree, did any change in the list													
9	Obtained necessary clearance													
	GN		Di.S		DS		FD		CEA		P.EA		A.Dep.	
10	Written inform to authorized officers/institutes													
	GN		Di.S		DS		FD		CEA		P.EA		A.Dep.	
11	IA agreed to closely monitor of tree removals (in written)													
12	Awareness on tree removals carried out for contractor to the satisfaction of PMU.													

GN- Grama Niladhari, Di.S – Divisional Secretary, DS – District Secretary, FD – Forest Department, CEA- Central Environment Authority, P.EA- Provincial Environment Authority, A.Dep. – Archeology Department, IA- Implementing Agency, PMU – Project management Unit. (Use “√” mark in relevant box)

..... According to the checklist, proposed tree removal is in order.

Signature / Date

Environment Specialist (IWWRMP)

.....
Signature /Date

Project Director (IWWRMP)

Declaration of Implementing Agency

I hereby certify that, proposed tree removal will be done under my direct supervision and responsible to maintain and follow required condition given by authorized / approving agencies.

.....

Signature /Date

Officer In-charge/ IA

Reference Only

Section - 7

Form of Bid

Section 7 - FORM OF BID

Name of Contract: Improvements to Sinnanai Anicut with gate arrangements in Ampara District
Contract No.: LK-MOMDE-539131-CW-RFB
 To: Project Director, Integrated Watershed & Water Resources Management Project

Gentlemen:

1. Having examined the Standard Bidding Document - Procurement of Works – Major Contracts [ICTAD/SBD/02 - Second Edition, January 2007], Specifications, Drawings and Bills of Quantities and Addenda for the execution of the above-named Works, we the undersigned, offer to execute and complete such Works and remedy any defect therein in conformity with the aforesaid Conditions of Contract, Specifications, Drawings, Bills of Quantities and addenda for the sum of Sri Lankan Rupees

 (LKR) or such other sums as may be ascertained in accordance with the said Conditions.
2. We acknowledge that the Contract Data forms part of our Bid.
3. We undertake, if our Bid is accepted, to commence the Works as soon as is reasonably possible after the receipt of the Engineer’s notice to commence, and to complete the whole of the Works comprised in the Contract within the time stated in the Contract Data.
4. We agree to abide by this Bid until the date specified in ITB Clause 16 [insert date], and it shall remain binding upon us and may be accepted at any time before that date.
5. Unless and until a formal Agreement is prepared and executed this Bid, together with your written acceptance thereof, shall constitute a binding Contract between us.
6. We understand that you are not bound to accept the lowest or any bid you may receive.
7. We declare that civil work contracts *have/ have not been* suspended or terminated and/or performance security called by an employer for reasons related to the non-compliance of any environmental, or social, (including sexual exploitation and abuse (SEA) and gender based violence (GBV)), or health or safety requirements or safeguard in the past five years.
 (*Note: If suspended, terminated or Performance Security is called give details*)

Year	Suspended or terminated portion of contract	Contract Identification	Total Contract Amount (current value, currency, exchange rate and US\$ equivalent)
[insert year]	[insert amount and percentage]	Contract Identification: [indicate complete contract name/ number, and any other identification] Name of Employer: [insert full name] Address of Employer: [insert street/city/country] Reason(s) for suspension or termination: [indicate main reason(s) e.g. for GBV/ SEA breaches]	[insert amount]

...	...	<i>[list all applicable contracts]</i>	...
Performance Security called by an employer(s) for reasons related to ESHS performance			
Year	Contract Identification		Total Contract Amount (current value, currency, exchange rate and US\$ equivalent)
<i>[insert year]</i>	<i>Contract Identification: [indicate complete contract name/ number, and any other identification]</i> <i>Name of Employer: [insert full name]</i> <i>Address of Employer: [insert street/city/country]</i> <i>Reason(s) for calling of performance security: [indicate main reason(s) e.g. for GBV/ SEA breaches]</i>		<i>[insert amount]</i>

8. We certify/confirm that we comply with the eligibility requirements as per ITB Clause 3 of the bidding documents.

Dated this day of.....20.....

Signature in the capacity of

duly authorized to sign bids for and on behalf of
[in block capitals or typed]

Address:

Witness:

Section – 8
Bill of Quantities

Reference Only

Schedules

Preamble to the Bill of Quantities
Description of Items and Measurement Methods
Bill of Quantities

Preamble to the Bill of Quantities

- 1.1 The Bill of Quantities shall be read in conjunction with all parts of this entire Bidding Document; the Instructions to Bidders, General and Particular Conditions of Contract, Technical Specifications, Drawings, and supplementary information.
- 1.2 The Bill of Quantities includes lump sum items, unit price items and provisional sum items. The lump sum price quoted will be deemed to be full compensation for completion of work items and paid in full when the work is completed. The quantities given in the Bill of Quantities for the unit price items are estimated and provisional, and are given to provide a common basis for bidding. They are not intended to be the maximum or minimum quantities for payment. The unit prices will be considered full compensation for those work items. The basis of payment will be the actual quantities of work carried out under the provisions of the Contract, measured and valued at the applicable rates and prices in the priced Bill of Quantities.
- 1.3 The rates and prices bid in the priced Bill of Quantities shall, except as otherwise provided under the Contract, include all construction plant, equipment, labour, supervision, materials, transport, erection, maintenance, testing, insurance, overheads, profit, taxes, and duties, together with all general risks, liabilities, and obligations set out or implied in the Contract.
- 1.4 A rate or price shall be entered against each item in the priced Bill of Quantities, whether quantities are stated or not. The cost of items against which the Contractor has failed to enter a rate or price shall be deemed to be covered by other rates and prices entered in the Bill of Quantities.
- 1.5 The rates and prices entered in the Bill of Quantities shall be full compensation for completed work and shall have taken full account of all requirements and obligations, covered by all parts of the contract, including but not limited to, the following, unless expressly stated otherwise:
 - a. All setting out and survey works including Pre and Post Construction Surveys.
 - b. All additional site surveys and investigations, preparation of field amendment drawings, shop drawings and As-Built drawings.
 - c. Mobilization and Demobilization of labour, all construction plant and equipment.
 - d. Establishment, Maintenance and Removal of all temporary facilities (Contractor's and Engineer's) including offices, workshops, houses, labour camps construction and storage yards, Laboratory facilities and Equipment, Transport for staff and labour etc.
 - e. Labour and all costs in connection therewith, including but not limited to social charges or fringe benefits.
 - f. The supply of material and goods, storage and costs in connection therewith including delivery to site and handling material within the site/sites.
 - g. Taking delivery of materials and goods supplied by others, unloading, storage, handling materials within site, and costs in connection therewith.
 - h. Construction Plant & Equipment and all costs in connection therewith.
 - i. Fixing, erecting and installing or placing of materials and goods in position, including usual auxiliary material etc.
 - j. Temporary Works.

- k. Complying with any limitations and constraints on the use of the site/sites including coordinating with other Contractor's, with regard to site access, security etc., maintenance of access to households and other users, maintenance of existing roads, waterways etc.
 - l. Dealing with the existing flow of water from any source including irrigation flow requirement, rainfall and surface runoff, groundwater, wave action and the like. This includes all and any dewatering operations necessary for the execution of the Works as well as coffer damming if required.
 - m. General obligations, liabilities and risks involved in the execution of the Works set forth or reasonably implied in the documents on which the tender is based.
 - n. Overheads and profit.
 - o. Waste of material.
 - p. Attendance and transport for surveys including provision of boats and survey instruments, sampling and testing carried out by the Engineer.
 - q. Performing all sampling and testing which are required to be carried out by the Contractor, and supplying results of such tests.
 - r. Providing required material delivery certificates.
 - s. Coordination with Regulatory Institutes & all stake holders.
 - t. Disposal of all waste material.
 - u. Complying with all requirements in Specifications and Conditions of Contract where separate items have not been provided.
- 1.6 Where Bill of Quantities items describe the replacement of existing equipment or components, including mechanical and electrical equipment, the equipment removed remains the property of the Employer, unless stated otherwise in the contract documents. The rates entered shall include for delivery of such equipment to the Employer or for disposal if so, directed by the Employer.
- 1.7 The whole cost of complying with the provisions of the Contract (excluding VAT) shall be included in the Items provided in the priced Bill of Quantities, and where no Items are provided, the cost shall be deemed to be distributed among the rates and prices entered for the related Items of Work.
- 1.8 General directions and descriptions of work and materials are not necessarily repeated nor summarized in the Bill of Quantities. References to the relevant sections of the Contract documentation shall be made before entering prices against each item in the priced Bill of Quantities.
- 1.9 Provisional Sums included and so designated in the Bill of Quantities shall be expended in whole or in part or not at all at the direction and discretion of the Engineer and in accordance with the Conditions of Contract. Where the expenditure against a Provisional Sum is made in the form of a Variation, the payment for the work will be made in accordance with Clause 13 of the Conditions of Contract.
- 1.10 The method and unit of measurement of completed work for payment shall be in accordance with the method described in the specifications for each item or in the Bill of Quantities. For Lump Sum items, measurements for Interim Payment Certificates shall be based on percentage completion of such item of work or milestone as per the Contractor's proposed schedule of monthly payments, as approved by the Engineer.

DESCRIPTIONS OF ITEMS AND MEASUREMENT METHODS

1 INTRODUCTION

The descriptions of the different items in the Bills of Quantities and the method adopted for measurements are indicated in the following paragraphs.

The quantities shall be computed using dimensions from the drawings based on the pre-construction surveys or as varied by the Engineer, except where clearly stated otherwise under the following individual items. No allowance shall be made for settlement, bulking, shrinkage, or waste.

BILL NO 1 - PRELIMINARIES

1.1 Securities, insurances etc.

Sub Item 1.1.1– Performance Security

The item provides for the provision of Performance Security as specified in Clause 4.2 of the Conditions of Contract.

Payments for the item will be certified when the Performance Security in the specified format has been provided and accepted by the Employer.

Sub Item 1.1.2– Providing Security bond, Advance bond and guarantees etc.

The item provides for the provision of Security bond, Advance payment Security as required in the Contract as a Provisional Sum item.

Payments for each item will be certified when the respective Advance payment security in the specified format has been provided and accepted by the Employer.

Sub Item 1.1.3, 1.1.4 - Insurances of property materials and works at site, third party insurance and Insurance against accidents, and injury to workmen

The sub items provide for the provision of the different types of insurances as specified in Clause 18 of the Conditions of Contract.

Payment for each type of insurance will be certified when the respective insurance policies from acceptable insurance companies together with full payment of the premium has been submitted to and accepted by the Employer.

1.2 Engineer's facilities for Implementing Agency

Sub Item 1.2.1 – Allow Provisional sum for constructing, maintaining, dismantling and removal on completion of the works, a temporary building of 10m x 4m for Engineer's office in conformity with the plans provided for Engineer's requirements including necessary furniture and fittings, furnishing, sanitary facilities and other facilities

The sub item provides for the provision for Construction of Engineer's 's site office, sanitary facilities, installation and supplying of electricity & water facilities of Engineer's offices for the duration of the Contract as a Provisional sum item. The Project Manager shall order the supply of items or the work items to be carried out under this provisional sum item. All items procured or established under this sub item shall remain the property of the Employer and shall be handed over to the Employer at the end of the Contract.

Sub Item 1.2.2 – Hiring of Double cab with fuel and driver for inspection works of Thambiluvil scheme and attend meeting in other Districts.(Engine Capacity 2500cc ,4WD, mileage less than 300,000 km , should be Brand new or registered after 01.01.2015)running shall be 3000km per month usage shall be 26 days per month, 06 days per week and 12 hours per day. air conditioner with rear AC vent minimum seating including driver shall be five.(Wet Lease basis with driver). Only for ten months period will be instructed by Engineer.

This sub-item covers the provision of a transport vehicle for the Employer's quality control staff, including transportation for quality assurance testing within the district and attending the meeting and official work out of the district. The vehicle must be a double-cap with dual air conditioning, and the scope includes the cost of the driver, fuel, maintenance, and up to 3,000 km of monthly usage, with the vehicle being used for 26 days per month (6 days per week).

Requirement for vehicle is only for 9 months and the payment amount be based on the actual progress. Required period will be decided by Engineer.

1.3 Contractor's Requirements

Sub item 1.3.1 – Allow Lump sum for constructing, maintaining, dismantling and removal on completion of the works, a temporary site office (10m x 5m) of adequate size including staff rest room and toilets and other facilities for the contractor's site managements staff in accordance with the plans prepared by the contractor and concurred by the Engineer.

The sub item provides for the establishment, maintenance and removal on completion of all the facilities required by the Contractor for execution of the works under the contract offices etc (details with layout to be supplied with the Tender). The Contractor shall submit with the Tender a breakdown of this Provisional sum item.

50 % of the lump sum under this item will be certified on establishment of all planned facilities balance of 25% for maintenance and the balance of 25% for when they have been removed and site cleaned on completion of the work. All items established under this item will remain the property of the Contractor.

Payments for maintenance under this item shall be included in the monthly payment certificates from the time the facilities have been established until completion.

Sub item 1.3.2 – Allow for constructing, maintaining, dismantling and removal on completion of the works, building to be used as workshop and stores for perishable materials and building shall be (8.0m x 5.0m) constructed in accordance with the drawings prepared by the contractor and concurred by the Engineer, the lump sum shall be also included for altering, modifying or dismantling and re-erecting within the site all temporary building / structures if required.

The sub item provides for the establishment, maintenance and removal on completion of all the facilities required by the Contractor for execution of the works under the contract including offices, stores, workshops, housing etc (details with layout to be supplied with the Tender). The Contractor shall submit with the Tender a breakdown of this Provisional sum item.

50 % of the lump sum under this item will be certified on establishment of all planned facilities balance of 25% for maintenance and the balance of 25% for when they have been removed and site cleaned on completion of the work. All items established under this item will remain the property of the Contractor.

Payments for maintenance under this item shall be included in the monthly payment certificates from the time the facilities have been established until completion.

1.4 Other requirements

Sub Item 1.4.1 - Provisional sum for all cost in connection with preparing samples for testing, making arrangements for testing of materials, goods etc., as stipulated in the specification, obtaining test reports and submitting the same to the Engineer

The sub item is provided as a provisional sum item for the reimbursement of preparing samples for testing, making arrangements for testing of materials, goods etc.

Payments under this item will be certified on production of the relevant documents of proof of payment.

Sub Item 1.4.2– Allow lump sum for maintaining the site by removal of all rubbish and debris in a clean and orderly manner on completion time and during the entire contract period.

The sub item is provided as a Provisional sum for removal of all rubbish and debris and disposal as approved and clearing site on completion.

Payment for this item will be certified on completion and leaving all in good order before handing over.

Sub Item 1.4.3 – Allow lump sum for provision of progress report including photo graphics records and other schedule included in the ICTAD publication Guideline for effective construction management (ICTAD/CM/01), relevant to contract administration as directed by the Engineer.

The sub item is provided as a Provisional sum for the submission of Monthly Progress Reports and photographs, schedules etc. Payments will be certified on a monthly basis on submission of the required documentation, accepted by the Engineer.

Sub Item 1.4.4 – Allow lump sum for provision of 2 set of (hard copies and soft copies) As-built drawing of all services, for engineer's approval

The sub item is provided on a Lump sum basis for the submission of As-Built Drawings, Quality Assurance reports and O & M Manual etc. as specified in the Contract and requested by the Engineer.

Payments will be certified on submission and acceptance of the required drawings and documents.

Sub Item 1.4.5– Employers share of Adjudicator's fees and expenses

This sub item is provided as a provisional sum for the reimbursement of the Employer's part of fees and expenses, paid by the Contractor to the Adjudicator.

Payments will be certified on submission of the required documentation, accepted by the Engineer.

Sub Item 1.4.6 Conducting Social awareness Programme with the coordination of implementing agency.

The sub item is provided on a provisional sum basis for the conducting social awareness programme. The contractor has to take all arrangement for this programme based on the instruction given by the implementing agency

Payments will be certified on submission of the required documentation, accepted by the Engineer.

Sub Item 1.4.7 Supply and installation of a real-time water level measuring device for Sagamam Tank located in the Thirukkivil Divisional Secretariat (DS) Division in two locations (Upstream and Downstream). The work included supporting post/structure and all required accessories for proper installation at the tank, a data transmission system to send real-time water level information to remote locations, and three display units, including 32-inch LED TVs to display the water level readings.

The sub item is provided on a provisional sum Supply and installation of a real-time water level measuring device for Sagamam Tank located in the Thirukkivil Divisional Secretariat (DS) Division in two locations (Upstream and Downstream). The work included supporting post/structure and all required accessories for proper installation at the tank, a data transmission system to send real-time water level information to remote locations, and three display units, including 32-inch LED TVs to display the water level readings. The display LED TV have to be fixed at Thambiluvil, Kalmunai and Batticaloa offices. The post measurements have to be discussed with the Engineer and get approval before fixing

Payments will be certified on submission of the required documentation and bills, accepted and approved by the Engineer and for the work on the LED TV and water level measuring device. The transport charges will not be provided 10% of profit will be provided.

Sub Item 1.4.9 Implementation of specific ESMP recommendation identified under ESMP/ESSR as directed by Engineer. Rate shall not include the general Environment, Social, Health and safety provision, where it shall be included in the respective rates

Item will be paid on actual basis as per the expenses incurred at submission of original invoice.

2.0 CONSTRUCTION OF COFFER DAMMING AND REMOVING AFTER CONSTRUCTION

Sub Item 2.1 - Alignment river for diverting channel along both sides of river as directed by machinery (As by Engineer) lift 0-1.5m.

The sub-item provides for Earth excavation for the diversion of river and store the Material including Transport haul -0.4 Km (0m-1.5m) and refill again the diversion channel after completion of work or any time instructed by the engineer. The rate includes the cost for excavation in any material except hard and soft rock areas, and the excavated material stockpiling for reuse as directed by the Engineer.

The measurement for payment shall be the volume of excavation measured from the levels established by the pre-construction surveys and as-built drawings.

Sub Item 2.2 - Furnishing, placing & laying sand filled pohora bag to coffer dam as directed by manually.

The sub-item provides for the placement of sand filled pohora bags as shown in the drawing or as directed by the engineer to safeguard the copper from damaged by water waves of rain water. The rate includes the cost for supplying of pohora bags to site the size approved by the engineer and tying with yarn or other material properly. The measurement for payment shall be the numbers of pohora bags laid for the copper dam as-built drawings

Sub Item 2.3 - Earth excavation from borrow and forming coffer dam as directed. (by machinery.)

The sub item provides for earth fill in copper dam slopes and top, using earth from selected borrow areas, including excavation from borrow areas, transporting, spreading, watering, compacting (98 % Proctor Density). The rate includes stripping and removing top soil from borrow areas and reinstatement of the same as directed by the Engineer. Rate shall also include for all charges, levies license fees etc. involved in borrow and transport of fill material and also removal of roots and other unwanted materials in borrowed soil.

The measurement for payment shall be the total compacted volume of earth fill in place, based on the preconstruction levels surveyed after clearing of slopes and the final design slope profile.

Sub Item 2.4 - Removing coffer dam after the construction as directed by machinery

The sub item provides for the removal of copper dam and bring back to the river in existing condition before the construction start and spoil to the material as waste at a nearest place with 30 km shown by the engineer.

The measurement for payment shall be the total compacted volume of earth fill in the copper dam.

3.0 - Improvements of Sin Anai Regulator (10+1) 11 Bay Anicut

Sub Item 3.1 - Shrub & thorny jungle clearing with uprooting and burning in up stream & downstream of proposed Flank bund area along both sides of river as directed by machinery.

This sub-item covers the clearing of shrubs and thorny jungle along the tank bund, including the upstream slope, downstream slope, and top of the bund. The cleared material (spoils) shall be disposed of outside the designated reservation area, as directed by the Engineer. Payment will be based on the actual area cleared, measured from the levels approved by the Engineer.

Sub Item 3.2 Demolishing cement concrete work including removing debris etc.

The sub item provides for breaking the existing concrete surface of the existing damaged anicut up to the required level of the anicut without damaging the remaining portion (using manual or hand breaker), the rate including the disposal of old concrete parts at the nearest place around 30 m as directed by the Engineer

The measurement for payment shall be the machinery hours that were used for demolishing work approved by the Engineer

Sub Item 3.3 Rubble masonry in cement, demolished, rubble staked and debris cleared.

The sub item provides for breaking the existing Rubble wall of the existing damaged anicut up to the required level of the anicut without damaging the remaining portion (using manual or hand breaker), the rate including the disposal of old concrete parts at the nearest place around 30 m as directed by the Engineer

The measurement for payment shall be the machinery hours that were used for demolishing work approved by the Engineer.

Sub Item 3.4 Cutting the cement concrete work the including removing debris etc.

The sub item provides for cutting existing concrete for groves to move the gate the grove size approximately 90 mm x 90mm x 90mm (using a hand electric cutter), the rate including the disposal of old concrete parts at the nearest place around 30 m as directed by the Engineer

The measurement for payment shall be the complete cutting of the groves, with a maximum length of 20 m.

Sub Item 3.5 – Supplying and fixing of 16mm Ø . 0.45 m long mild steel dowels including drilling and grouting.

The sub-item provides for furnishing and placing 0.45m long 16 mm dia Tor Steel dowel bars (if required) using chemical adhesive including boreholes for 0.25m as directed. Detail Drawing annexed. The measurement for payment shall be No of dowels placed as directed by the Engineer.

Sub Item 3.6 - Common earth excavation in construction area of foundation by machinery. Up to 1.5m depth.

The sub-item provides for Earth excavation in anicut section and spoils to waste or fill Material including Transport haul -0.4 Km (0m-1.5m). The rate includes the cost for excavation in any material except hard and soft rock areas, and the excavated material off site or stockpiling for reuse as directed by the Engineer.

The measurement for payment shall be the volume of excavation measured from the levels established by the pre-construction surveys and as-built drawings. The working space will not consider for payment.

Sub Item 3.7 - Soft rock excavation in foundation and part refill by machinery (lift 0-1.5m)

The sub-item provides for soft rock or any other hard material in same nature excavation in cut off wall section and spoils to waste or fill Material including Transport haul -0.4 Km (0m-1.5m). The rate includes the cost for excavation in any material except hard areas, and the excavated material spoil to waste. The measurement for payment shall be the volume of excavation measured from the levels established by the pre-construction surveys and as-built drawings. The working space will not consider for payment.

Sub Item 3.8 - Shoring with 3mm thick mild steel plate with 100mm X 50mm H iron upright up to 2.0m depth for each 3 uses including fixing & removing same once.

The sub-item provides for making shoring arrangement by using 3mm thick mild steel plate with 100mm X 50mm H iron.

The measurement for payment will be based on the area of the shoring arrangement provided for the excavation trench. The shoring arrangement must be approved by the Engineer

Sub Item 3.9 - Supplying, placing & spreading gravel between the cutoff wall (Under the sill concrete) including watering as directed.

The sub-item provides for supplying and placing and spreading gravel as directed by the Engineer.

The measurement for payment shall be the volume of sand filed and the measurement taken from the levels established by the pre-construction surveys and as-built drawings.

Sub Item 3.10 – Allow for dealing with water during the construction using with submerge pump (3.0" Pump and 8.0 h/days)

The sub-item provides for Allow for dealing with water during the construction using 75mm dia sub merge pumps as directed by the Engineer. The rate includes all costs related to this operation. The payment shall be the operating hours of sub-merge Pumps approved by the Engineer

Sub Item 3.11 – Supplying and placing of 1000-gauge polythene sheet of under the concrete.

The sub-item provides for furnishing and placing of 1000-gauge polythene under concrete base to separate the earth and concrete as directed.

The measurement for payment will be based on the base concrete area of the structure where polyethylene is used for the concrete, as directed by the Engineer

Sub Item 3.12 – 1:2:4 (20mm) mass concrete in structure including placing, compacting and necessary curing arrangement. Form work paid separately.

The sub-item provides for 1:2:4 (20mm) concrete (Grade 20) in structure including placing, compacting with a poker vibrator and necessary curing arrangement as directed (mixing by machinery) Formwork paid separately.

The payment measurement shall be the concrete volume measured from the as-built drawings approved by the Engineer.

Sub Item 3.13 – 1:2:4 (20mm) Grade 20 ct. concrete in structure including placing, compacting and necessary curing arrangement. Form work paid for separately.

The sub-item provides for 1:2:4 (20mm) concrete (Grade 20) in structure including placing, compacting with a poker vibrator and necessary curing arrangement as directed (mixing by machinery) Formwork paid separately.

The payment measurement shall be the concrete volume measured from the as-built drawings approved by the Engineer

Sub Item 3.14 Furnishing and making form work for each the uses including fixing and removing same once.

The sub-item provides for Furnishing and making formwork with steel formwork or 16mm thick in plywood or using class 11 timber and necessary props for each of six uses including fixing and removing same once. supplying all necessary formwork, erecting, framing, cutting angles, cleaning wetting and treatment before placing concrete and removal.

The measurement for payment shall be the formwork area of concrete measured from the as-built drawings.

Sub Item 3.15 – Furnishing. Cutting. bending and placing 10mm,12mm dia tor steel reinforcement in position. (as directed by Engineer)

The sub-item provides for Furnishing Cutting, bending, fabricating, placing and binding by winding wire of tor steel reinforcement in passion as per drawings including cover blocks. (rate should include the lab lengths)

The measurement for payment shall be the weight of QT rib bars measured from the as-built drawings.

Sub Item 3.16 – Supplying and fixing 75mm x75mm x6mm ' L' iron as directed including 225mm long anchor welded to ' L' iron at 600mm interval for bonding arrangement.)

The sub-item provides for supplying and fixing 75mm x75mm x6mm ' L' iron to the grove of the pier of the Anicut and the rate including for the anchor of L iron in to the pier concrete by welding of 225 mm long L iron at 600 mm intervals. The measurement for payment shall be length of the L iron fixed on pier measured from the as-built drawings.

Sub Item 3.18 – Supplying and Fixing 16mm Dia, 0.30m Long bolt & Nut for fixing "H" Iron.
The sub-item provides for supplying and fixing 16 mm Dia, 0.30m Long bolt & Nut for fixing "H" Iron.

The measurement for payment shall be numbers of bolt fixed based on the position marked in the construction drawing or as directed.

Sub Item 3.19 – Furnishing and fixing steel regulator gate to anicut bays as per detail drawings (No. - 527 - 2 - 6D)

The sub-item includes fabrication, supply and installation of a steel gate to the anicut, as per the details provided in the drawing.

Payment measurements will be based on the area of the gate installed. Additionally, the proper operation of the gate within the groove of the anicut pier must be ensured and approved by the engineer.

Sub Item 3.20 – Supply and fixing hoisting Gear arrangement (Gear ratio 5:1) with 50mm dia spindle Rod for including thread cutting to the steel regulator gate as per the detailed drawings and required length

The sub item provides for Supplying and Fixing Hoisting Gear arrangement (Gear ratio 5:1) with 50mm dia spindle Rod for a required length including thread cutting to steel regulator gate as per detail drawings as directed by Engineer.

The measurement for payment shall be the number of hoisting Gear fixed and approved by the Engineer.

Sub Item 3.21 – Supplying and Fixing 200mm X 100mm “H” Iron to the top of pier for gate lifting arrangement.

The sub-item provides for supplying and fixing 200 mm x 100 mm x 6mm ' H' iron to the top of the pier of the Anicut .

The measurement for payment shall be length of the H iron fixed on pier measured from the as-built drawings

Sub Item 3.22 – Providing of 50 x 100 weep holes in abutment of Anicut with filter arrangement as per type plan No.C-470-3-6D (as directed by Engineer)

The sub-item provides for Supplying and Placing of 50mm Dia and maximum 1200mm long (1000type) PVC pipe weep holes to drain out water. The measurement for payment shall be the number of weep holes approved by the engineer

Sub Item 3.23 - Supplying and fixing 75mm x75mm x6mm ' L' iron hand rail on passaral including bending and fixing charges as directed.

The sub item is provided fabricating and fixing guard rail for passaral by using heavy duty 75mm x 75mm x 6mm “L” iron approved by the engineer and measurements and sizes shown in the drawings Payment for this item will be certified on the completed length of guard rails shown in the drawing

Sub Item 3.24 – Earth excavation from borrow and forming Tank bund to profile including watering and compaction lift 0-5m, (by machinery , compaction more than 98% , the vertical thickness not more than 300mm)

The sub item provides for earth fill around the structures, using earth from selected borrow areas, including excavation from borrow areas, transporting, spreading, watering, compacting (98 % Proctor Density) and specified or directed material testing. The rate includes stripping and removing top soil from borrow areas and reinstatement of the same as directed by the Engineer. Rate shall also include for all charges, levies license fees etc. involved in borrow and

transport of fill material and also removal of roots and other unwanted materials in borrowed soil. The measurement for payment shall be the total compacted volume of earth fill in place, based on the preconstruction levels surveyed after clearing of slopes and the final design level.

Sub Item 3.25 - Furnishing and fixing 9" wide centre blub type rubber water bar

The sub item is provided supplying and fixing of Water bar approved by the engineer and measurements and sizes shown in the drawings

Payment for this item will be certified on the completed length of water bar shown in the drawing and the same fixed by contractor

4.0 CONCRETE ROAD FOR SAGAMAM TANK

Sub Item 4.1 - Trimming, levelling and compaction of original ground/subgrade to 95% using motor grader

The sub-item provides for Trimming, Levelling, including removal of loose soil and debris, and compaction by a suitable roller to a minimum 95% of compaction as directed by the Engineer. The motor grader is used for this levelling work

The measurement for payment shall be the effective area of the road surface level and compacted.

Sub Item 4.2 – Dense Graded Aggregate base course spreading watering and compacting graded 37.5mm aggregate to form a dense aggregate base for road

Dense Graded Aggregate Base Course (37.5 mm nominal size) shall be measured in cubic metres (m³) of material compacted in place, calculated from the net plan area and the specified compacted thickness shown on the drawings, in accordance with the Specifications of the Construction Industry Development Authority (CIDA), Sri Lanka. Measurement shall be based on the finished compacted dimensions within the approved lines, levels, widths and thicknesses. The rate shall be deemed to include supplying approved ABC, loading, transporting, spreading in layers, watering to optimum moisture content, grading, and compacting to the specified density, including all labour, plant, testing and incidentals necessary to complete the work to the satisfaction of the Engineer. No allowance shall be made for loose thickness, overfilling, wastage, or material placed outside the specified limits, and payment shall be made only for work properly completed and accepted. The measurement for payment will be based on the compacted volume as directed by the Engineer.

Sub Item 4.3 – Supplying and placing of 1000-gauge polythene sheet of under the concrete.

The sub-item provides for furnishing and placing of 1000-gauge polythene under concrete base to separate the earth and concrete as directed.

The measurement for payment will be based on the base concrete area of the structure where polyethylene is used for the concrete, as directed by the Engineer

Sub Item 4.4 – Shuttering and dismantling to surface area, including class II timber joists and necessary props.

The sub-item provides for Furnishing and making formwork with steel formwork or or using class 11 timber and necessary props for each of six uses including fixing and removing same once. supplying all necessary formwork, erecting, framing, cutting angles, cleaning wetting and treatment before placing concrete and removal.

The measurement for payment shall be the formwork area of concrete measured from the as-built drawings.

Sub Item 4.5 – 1:2:4 (20mm) mass concrete in structure including placing, compacting and necessary curing arrangement. Form work paid separately.

The sub-item provides for 1:2:4 (20mm) concrete (Grade 20) in structure including placing, compacting with a poker vibrator and necessary curing arrangement as directed (mixing by machinery) Formwork paid separately. The payment measurement shall be the concrete volume measured from the as-built drawings approved by the Engineer.

Sub Item 4.6 – Mild steel 6 mm rods in reinforcing, laid in position and tied with G.I. Wire at 200mm intervals both ways. Including transport and lapping

The sub-item provides for Furnishing Cutting, bending, fabricating, placing and binding by winding wire of tor steel reinforcement in passion as per drawings including cover blocks. (rate should include the lab lengths). The measurement for payment shall be the weight of QT rib bars measured from the as-built drawings.

Sub Item 4.7 – Expansion joint to every 6.00m intervals with 25 mm thick regiform with bitumen Sand mixture after removal of regiform. Including the cost of bitumen and transport

The sub-item provides for proving expansion joint, the thickness of 25 mm has to be constructed with regiform then filled with bitumen and sand mixture. After the removal of regiform, the rate includes all costs, including clearing of regiform, supply and transport of materials

The measurement for payment shall be the completed length of the expansion joint, as specified and satisfactory to the Engineer.

Sub Item 4.8 - Tidying up site for after completion of work

The sub item is provided as a lump sum for the removal of all rubbish and debris and disposal as approved, and clearing the site on completion.

Payment for this item will be certified on completion, leaving all in good order before handing over

2 DAYWORKS PAYMENTS

Labour

Payment in respect of labour employed on a day work basis shall be made at the average daily wage rates (inclusive of contractor's overheads and profits) in construction as entered by the Bidder in the relevant BOQ. Payment shall be made on the basis of the actual time worked excluding travelling time.

The rates shall be deemed to include the costs of the Contractor's Site Supervisory and Administrative Staff (including supervising Foremen) and all other costs in respect to the employment of labour on a day work basis. Rates for types of labour not listed will be determined by the Engineer by reference to the listed rates.

Materials

Payment in respect of materials used in the execution of work on day work basis shall be the cost of the materials delivered to store or stockpile on the site, including all overheads and profit. Rates should be entered by the Bidder in the relevant BOQ.

Rates shall be deemed to cover the costs of taking delivery and putting into store or stockpile, storage, overheads, profit and all other charges and costs in respect of the procurement and

handing of such materials. Rates for other materials will be determined by the Engineer with reference to the listed rates entered in the BOQ.

Construction Plant and Equipment

Payment in respect of constructional plant deployed on a day work basis shall be made at the rates entered by the Bidder in the relevant BOQ. These rates shall be deemed to include all cost in respect of fuel and consumable stores, maintenance, operators and attendants, contractor's site supervisory and administrative staff, overheads, profit and all other charges and costs in respect of the deployment of constructional plant and equipment on a day work basis.

Payment shall be made on the basis of the actual time worked including such reasonable travelling time as the Engineer may allow, but excluding idle time (except under the orders of the Engineer.) and time during which such constructional plant/equipment is broken down or undergoing maintenance. Rates for other plant/equipment will be determined by the Engineer with reference to the listed rates entered in the BOQ.

Reference Only

Bill of Quantities

SUMMARY

Item No.	Description	Amount (LKR)
1	Preliminaries	
2	Construction of Coffe damming and removing after construction.	
3	Improvements of Sin Anai Regulator 11 Bay Anicut	
4	Concrete road for Sagamam tank	
A	Sub Total - Summary of Bills 1 to 5	
5	Provisional Sum – Total for Day works	3,250,000.00
6	Sub Total 2 (3-4)	
7	Discount (If Any)	
8	Sub Total 3 (5-6+4)	
9	Physical Contingencies [10% of (7)]	
10	Price Contingencies [4% of (7)]	
11	Total Bid Price, Carried To Letter Of Bid (7+8+9)	
Total Bid Price (Amount in Words)		
12	VAT (18% of 10)	
13	Total Estimate Cost (10+11)	
14	Total for Day Works	
15	Bid Price with Day Works (12+13) (Will be considered only for Evaluation Purpose)	

Bill of Quantities

Item No	Description	Unit	Qty	Rate (LKR)	Amount (LKR)	Rate in Words
1.0	Preliminaries					
	The attention of the bidder is drawn to the use of Bill of Quantities, Drawings, Conditions of Contract, Specifications and any other particulars related to this bid. It is the bidder's responsibility to see that his price includes for complying with all the requirements of the conditions of contract and other documents specifically required.		Note			
	The bidder is advised to visit the site of the proposed work, as it is his responsibility to ascertain the Conditions, governing access to the site, the external working space, storage area, etc.,		Note			
	Existing roads & culverts cannot take the passage of heavy vehicle or such in adequate areas to be strengthen by the successful bidder, before make use		Note			
	Any existing services, roads, culverts and approaches damaged during the construction to be reinstated without any charge to the employer.		Note			
	All temporary works shall be dismantled and cleared away from the site on completion of the work.		Note			
	Any other preliminary items not listed below but deemed to be included in the bid rates, as no extras would be made.		Note			
	No work in any trade shall be carried out in such a manner as to cause any nuisance to adjacent owners or the public		Note			

Item No	Description	Unit	Qty	Rate (LKR)	Amount (LKR)	Rate in Words
	Mechanical plant and equipment which emits obnoxious liquids, gases etc., will not be allowed to be used on the site, without the prior approval from the Employer and the Engineer.		Note			
	The Engineer has the final decision as and when he deems it necessary for the Contractor to take precautions, maintain or repair such plant and equipment or order their removal from the site.		Note			
	The contractor shall be responsible for any loss or damage to the works, existing structures, adjoining structures and unfixed materials.		Note			
	The Contractor shall be responsible for necessary lighting, watchman and other suitable measures during construction until handing over.		Note			
	Contractor shall be responsible for erection, shifting and maintaining of necessary protective netting, fencing, hording, screens at site and other precautions to the required standard and satisfaction of the Engineer.		Note			

Item No	Description	Unit	Qty	Rate (LKR)	Amount (LKR)	Rate in Words
1.0	Item - A, Preliminaries					
1.1	Securities, Insurances etc.,					
1.1.1	Provisional sum for providing a Performance Security.(amount to be included by the Employer/Consultant)	Allow	Item	P.Sum	210,000.00	
1.1.2	Security bond, Advance bond and guarantees etc. (amount to be included by the Employer/ Consultant)	Allow	Item	P.Sum	200,000.00	
1.1.3	Provisional Sum for insurance of works, Machinery & Equipment, Plant, Materials, third party persons & property and Employer's personnel & property at site as per the contract (amount to be included by the Employer/ Consultant)	Allow	Item	P.Sum	180,000.00	
1.1.4	Insurance against accidents and injury to contractor's personnel as per the contract. (amount to be included by the Employer/ Consultant)	Allow	Item	P.Sum	180,000.00	
1.2	Engineer's facilities for Implementing Agency					
1.2.1	Allow Provisional sum for constructing, maintaining, dismantling and removal on completion of the works, a temporary building of 10m x 4m for Engineer's office in conformity with the plans provided for Engineer's requirements including necessary furniture and fittings, furnishing, sanitary facilities and other facilities.	Allow	Item	P.Sum	100,000.00	

Item No	Description	Unit	Qty	Rate (LKR)	Amount (LKR)	Rate in Words
1.2.2	Hiring of Double cab with fuel and driver for inspection works of Thambiluvil scheme and attend meeting in other Districts. (Engine Capacity 2500cc ,4WD, mileage less than 300,000 km , should be Brand new or registered after 01.01.2015)running shall be 3000km per month usage shall be 26 days per month, 06 days per week and 12 hours per day. air conditioner with rear AC vent minimum seating including driver shall be five. (Wet Lease basis with driver). Only for ten months, period will be instructed by Engineer	Allow	Item	L.Sum		
1.3	Contractor's Facilities					
1.3.1	Allow Lump sum for constructing, maintaining, dismantling and removal on completion of the works, a temporary site office (10m x 5m) of adequate size including staff rest room and toilets and other facilities for the contractor's site managements staff in accordance with the plans prepared by the contractor and concurred by the Engineer.	Allow	Item	L.Sum		
1.3.2	Allow for constructing, maintaining, dismantling and removal on completion of the works, building to be used as workshop and stores for perishable materials and building shall be (8.0m x 5.0m) constructed in accordance with the drawings prepared by the contractor and concurred by the Engineer, the lump sum shall be also included for altering, modifying or dismantling and re-erecting within the site all temporary building / structures if required.	Allow	Item	L.Sum		

Item No	Description	Unit	Qty	Rate (LKR)	Amount (LKR)	Rate in Words
1.4	Other Requirements					
1.4.1	Allow Provisional sum for all cost connection with preparing samples for testing, making arrangements for testing of materials, goods etc. as stipulated in the specification, obtaining test reports and submitting the same to the Engineer.	Allow	Item	P.Sum	120,000.00	
1.4.2	Allow lump sum for maintaining the site by removal of all rubbish and debris in a clean and orderly manner on completion time and during the entire contract period.	Allow	Item	L. Sum		
1.4.3	Allow lump sum for provision of progress reports including photographic records and other schedules included in the ICTAD publication - Guidelines for effective Construction Management. (ICTAD/CM/01), relevant to contract administration as directed by Engineer.	Allow	Item	L.Sum		
1.4.4	Allow lump sum for provision of 4 set of (hard copies and soft copies) As-built drawing of all services, for engineer's approval	Allow	Item	L. Sum		
1.4.5	Employers share of Adjudicator's fees and expenses	Allow	Item	P.Sum	300,000.00	
1.4.6	Conducting Social awareness Programme with the coordination of implementing agency	Allow	Item	P.Sum	100,000.00	

Item No	Description	Unit	Qty	Rate (LKR)	Amount (LKR)	Rate in Words
1.4.7	Supply and installation of a real-time water level measuring device for Sagamam Tank located in the Thirukkivil Divisional Secretariat (DS) Division in two locations (Upstream and Downstream). The work included supporting post/structure and all required accessories for proper installation at the tank, a data transmission system to send real-time water level information to remote locations, and three display units, including 32-inch LED TVs to display the water level readings	Allow	Item	P.Sum	1,700,000.00	
1.4.8	Forestation as directed by Engineer.	Allow	Item	P.Sum	10,000.00	
1.4.9	Implementation of specific ESMP recommendation identified under ESMP/ESSR as directed by Engineer. Rate shall not include the general Environment, Social, Health and safety provision, where it shall be included in the respective rates	Item	Allow	P.Sum	150,000.00	
Total for Bill No 1 (Carried to Summary of Bill)						
2.0	Bill II -Construction of Coffe damming and removing after construction.					
2.1	Alignment river for diverting channel along both sides of river as directed by machinery (As by Engineer)	m ³	180.00			
2.2	Furnishing, placing & laying sand filled pohora bag to coffer dam as directed by manually.	Nos	988.00			

Item No	Description	Unit	Qty	Rate (LKR)	Amount (LKR)	Rate in Words
2.3	Earth excavation from borrow and forming coffer dam as directed. (by machinery)	m ³	120.00			
2.4	Removing coffer dam after the construction as directed by machinery	m ³	360.04			
Total for Bill No 2 (Carried to Summary of Bill)						
3.0	Improvements of Sin Anai Regulator 11 Bay Anicut					
3.1	Shrub & thorny jungle clearing with uprooting and burning in upstream & downstream of proposed Flank bund area along both sides of river as directed by machinery.	Ha	0.01			
3.2	Demolishing cement concrete work including removing debris etc.(using manual or hand breaker)	m ³	21.87			
3.3	Rubble masonry in cement, demolished, rubble staked and debris cleared.(using manual or hand breaker)	m ³	15.26			
3.4	Cutting the cement concrete work the including removing debris etc.(using a hand electric cutter), grove size 90 mm x 90 mm x 90 mm length of maximum 20 m	Item	Allow	L. sum		
3.5	Supplying and fixing of 16mm Ø. 0.45 m long mild steel dowels, including drilling and grouting.	Nos	271.00			
3.6	Common earth excavation in the construction area of the foundation by machinery. Up to 1.5m depth.	m ³	15.030			
3.7	Soft rock excavation in Canals & spoil to waste lift 1.5 - 3.0m	m ³	13.50			

Item No	Description	Unit	Qty	Rate (LKR)	Amount (LKR)	Rate in Words
3.8	Shoring with 3mm thick mild steel plate with 100mm X 50mm H iron upright up to 2.0m depth for each 3 uses including fixing & removing same once.	m ²	47.00			
3.9	Supplying, placing & spreading gravel between the cut-off wall (Under the sill concrete), including watering & 98% compaction as directed.	m ³	5.74			
3.10	Allow for dealing with water during the construction using a submersible pump (3.0" Pump and 8.0 h/days)	Hrs.	224.00			
3.11	Supplying and placing a 1000 gauge polythene sheet of under the concrete	m ²	51.06			
3.12	1:2:4 (20mm) mass concrete in structure, including placing, compacting and necessary curing arrangement. Form work is paid separately.	m ³	27.68			
3.13	1:2:4 (20mm) Grade 20 ct. concrete in structure, including placing, compacting and necessary curing arrangement. Form work is paid for separately.	m ³	67.30			
3.14	Furnishing and making form work for each three uses, including fixing and removing the same once.	m ²	320.41			
3.15	Furnishing. Cutting. bending and placing 10mm,12mm dia tor steel reinforcement in position.(as directed by the Engineer)	Kg	8,500.00			
3.16	Supplying and fixing 75mm x75mm x6mm 'L' iron as directed including 225mm long anchor welded to 'L' iron at 600mm interval for bonding arrangement.	Lm	97.34			
3.17	Construction of 90mm x 75mm groove arrangement for lifting the gate as directed	Lm	97.34			

Section 8 – Bill of Quantities

Item No	Description	Unit	Qty	Rate (LKR)	Amount (LKR)	Rate in Words
3.18	Supplying and fixing 16mm Dia, 0.30m Long bolt & Nut for fixing "H" Iron	No	96.00			
3.19	Furnishing and fixing the steel regulator gate to the Anicut Bays as directed and shown in the drawing	m ²	16.25			
3.20	Supply and fixing hoisting Gear arrangement (Gear ratio 5:1) with 50mm dia spindle Rod for including thread cutting to the steel regulator gate as per the detailed drawings and required length	No	11.00			
3.21	Supplying and Fixing 'H' Iron 200X100 (6mm) with necessary cleats to housing props including 2 coats of anticorrosive painting for Gate fixing Beam (Top of pier for gate lifting arrangement.)	Lm	25.60			
3.22	Providing 50mm dia PVC (Gauge - 1000) weep holes in the abutment of Anicut with a filter arrangement(as directed by the Engineer)	No	30.00			
3.23	Supplying and fixing 75mm x75mm x6mm 'L' iron handrail on passara, including bending and fixing charges as directed.	Lm	46.98			
3.24	Earth excavation from borrow and forming Tank bund to profile, including watering and compaction lift 0-5m, (by machinery, compaction more than 98% , the vertical thickness not more than 300mm)	m ³	125.00			
3.25	Furnishing and fixing 9" wide centre bulb-type rubber water bar	Lm	15.30			
Total for Bill No 3 (Carried to Summary of Bill)						

Item No	Description	Unit	Qty	Rate (LKR)	Amount (LKR)	Rate in Words
4.0	Concrete road for Sagamam tank					
4.1	Trimming, levelling and compaction of original ground/subgrade to 95% std using motor grader, including compaction	m ²	222.5			
4.2	Dense Graded Aggregate base course spreading, watering and compacting graded 37.5mm aggregate to form a dense aggregate base for the road. (haul-20.0km)	m ³	33.75			
4.3	Supplying & placing of 1000 gauge polythene under a concrete base.	m ²	225			
4.4	Shuttering and dismantling to surface area, including class II timber joists and necessary props.	m ²	16.2			
4.5	1:2:4(20mm) ct. concrete work in using concrete mixer and compacting with a paver vibrator, including curing, excluding formwork	m ³	33.75			
4.6	Mild steel 6 mm rods in reinforcing, laid in position and tied with G.I . Wire at 200mm intervals both ways. Including transport and lapping	kg.	461.76			
4.7	Expansion joint to every 6.00m intervals with 25mm thick regiform with bitumen Sand mixture after removal of regiform . Including cost of bitumen and transport (without dowels)	Lm	40.5			
4.8	Tiding up side	Item	Allow	L.Sum		
Total for Bill No 4 (Carried to Summary of Bill)						

5.0 DAYWORKS SCHEDULE

	Description	Unit	Qty	Rate (LKR)	Amount (LKR)	Amount in Words
	Labour					
1	Skilled labour	hr	50.00			
2	Unskilled labour	hr	60.00			
3	Mason	hr	20.00			
4	Carpenter	hr	10.00			
5	Plumber, Electrician	hr	15.00			
6	Mechanic	hr	15.00			
7	Welder, Fitter	hr	15.00			
8	Steel fixer	hr	15.00			
9	Driver	hr	50.00			
	Total for Labour					
	Material					
1	Cement (50 Kg bags)	Nos	100.00			
2	Sand	m ³	30.00			
3	Mild steel reinforcement	t	0.30			
4	Tor steel reinforcement	t	0.30			
5	Mild Steel Plate	t	0.15			
6	Stainless Steel Plate	t	0.15			
7	Fabricated Steelwork	t	0.15			
8	Timber Ply Sheet 12mm	m ²	30.00			
9	Gravel	m ³	50.00			
	Total for Material					
	Equipment					
1	Backhoe/Loader 100 HP	hr	20.00			
2	Mobile crane 30T	hr	10.00			
3	Dump truck / Tipper 20T	hr	10.00			
4	Tractor/Trailer 100HP	hr	10.00			
5	Concrete Mixer 1 m ³	hr	10.00			
6	Air Compressor 3-Tool	hr	5.00			
7	Welding Set 10KVA	hr	10.00			
8	Sandblasting Equipment	hr	15.00			
9	Diesel Generator 20KVA	hr	15.00			
10	Water Pumps 50mm	hr	25.00			
11	Excavator	hr	25.00			
	Total for Equipment					
Total for Bill No 06						

Technical Proposal

Forms for personnel

Forms for equipment

Site organisation

Method statements

Mobilisation and construction schedule

Forms for Personnel

Form PER – 1: Proposed Personnel

Bidders should provide the names of suitably qualified personnel to meet the specified requirements for each of the positions listed in Section III (Evaluation and Qualification Criteria). The data on their experience should be supplied using the form below for each candidate.

1.	Title of position Name
2.	Title of position Name
3.	Title of position Name
4.	Title of position Name
5.	Title of position Name
6.	Title of position Name
etc.	Title of position Name

Forms for Equipment

The Bidder shall provide adequate information to demonstrate clearly that it has the capability to meet the requirements for the key equipment listed in Section III (Evaluation and Qualification Criteria). A separate Form shall be prepared for each item of equipment listed, or for alternative equipment proposed by the Bidder. The Bidder shall provide all the information requested below, to the extent possible. Fields with asterisk (*) shall be used for evaluation.

Type of Equipment*	
Equipment Information	Name of manufacturer
	Capacity*
	Model and power rating
	Year of manufacture*
Current Status	Current location
	Details of current commitments
Source	Indicate source of the equipment <input type="checkbox"/> Owned <input type="checkbox"/> Rented <input type="checkbox"/> Leased <input type="checkbox"/> Specially manufactured

The following information shall be provided only for equipment not owned by the Bidder.

Owner	Name of owner	
	Address of owner	
	Telephone	Contact name and title
	Fax	Telex
Agreements	Details of rental / lease / manufacture agreements specific to the project	

Site Organisation

The Bidder shall provide a personnel chart for the proposed site organization, indicating the key positions as given in Section III (Evaluation and Qualification Criteria) and other positions, with names of personnel proposed and a description of the tasks assigned for such positions.

Reference Only

Method Statements

The Bidder shall provide a method statement describing the methodology proposed to be adopted in the execution of the contract.

Reference Only

Mobilisation and Construction Schedule

The Bidder shall provide a detailed mobilization and construction schedule indicating the sequence of all main operations and identifying critical activities.

Reference Only

Section 9 - Schedules

Schedule 1 – General Information			
<p>(i) <i>If pre-qualification is done the bidders are required to include information subsequent to that submitted with the pre-qualification application.</i></p> <p>(ii) <i>For joint ventures, each joint venture partner shall furnish information separately.</i></p>			
ITB Clause reference	Description	Information <i>(to be filled by the Bidder)</i>	Remarks
4.1 (a)	Legal Status		<i>Provide certified copies of Registration</i>
	Written power of attorney of the signatory to the Bid	<i>Provide original or certified copy of the power of Attorney attested by a Notary and label as attachment to Clause 4.1(a)</i>	
	If a Joint Venture, names and addresses of Joint Venture Partners	1. 2. 3.	<i>Provide a draft copy of the Joint Venture Agreement or alternatively the memorandum of understanding</i>
	If a Joint Venture, name of Lead Partner		
<i>For joint ventures, each joint venture partner shall furnish Legal Status separately</i>			
	Name (Lead partner)		<i>Provide certified copies and label as attachment to Clause 4.1(a)</i>
	Legal status		
	Place of registration		
	Principle place of business		
	Written power of attorney of the signatory to the Bid	<i>Provide original or certified copy of the power of attorney attested by a Notary and label as attachment to Clause 5.1</i>	
	VAT Registration Number		
	Name (Partner 2)		<i>Provide certified copies and label as attachment to Clause 4.1 (a)</i>
	Legal status		
	Place of registration		
	Principle place of business		

	Written power of attorney of the signatory to the Bid	<i>Provide original or certified copy of the power of attorney attested by a Notary and label as attachment to Clause 4.1 (a)</i>	
	VAT Registration Number		
	Name (Partner 3)		<i>Provide certified copies and label as attachment to Clause 4.1 (a)</i>
	Legal status		
	Place of registration		
	Principle place of business		
	Written power of attorney of the signatory to the Bid	<i>Provide original or certified copy of the power of attorney attested by a Notary and label as attachment to Clause 4.1 (a)</i>	
	VAT Registration Number		
4.2 (a)	ICTAD Registration		<i>Provide certified copies and label as attachment to Clause 4.2(a)</i>
	Registration number		
	Grade		
	Specialty		
	Expiry Date		

**Schedule 2 – Annual Turn-over Information
(Construction only – Last five years)**

- (i) *If pre-qualification is done the bidders are required to include information subsequent to that submitted with the pre-qualification application.*
- (ii) *For joint ventures, each joint venture partner shall furnish information separately.*

Year	Turn-over	Remarks
1		<i>Attach audited reports and label as attachment to Clause 4.2</i>
2		
3		
4		
5		

Schedule 3 – Adequacy of Working Capital

If pre-qualification is done the bidders are required to include information subsequent to that submitted with the pre-qualification application

Source of credit line	Amount	Remarks
		<i>Provide documentary evidence and label as attachment to Clause 4.2</i>
Total		

Schedule 4 – Construction Experience in last five years

(i) *If pre-qualification is done the bidders are required to include information subsequent to that submitted with the pre-qualification application.*

(ii) *For joint ventures, each joint venture partner shall furnish information separately.*

Year	Employer	Description of Works	Amount	Contractor's Responsibility (%)
		Total		

- *Provide documentary evidence and label as attachment to Clause 4.2*

Schedule 6 – Construction Management Staff		
A. Key Professionals		
Name	Position	Task
B. Support Staff		
Name	Position	Task

Schedule 9 – Input percentages for Price Adjustment Formula		
Input Name <i>(Include major materials below the list, together with percentages for all inputs)</i>	ICTAD Reference for Indices	Percentage <i>(percentages listed should added to 90.0)</i>
Total		

Nonadjustable element shall be:
All Psum & Lsum items

Schedule 10: ESHS Management Strategies and Implementation Plans

(ESHS-MSIP)

The Bidder shall submit comprehensive and concise Environmental, Social, Health and Safety Management Strategies and Implementation Plans (ESHS-MSIP) as required by ITB 13.1 A (j) and 13.1 B (d). These strategies and plans shall describe in detail the actions, materials, equipment, management processes etc. that will be implemented by the Contractor, and its subcontractors.

Code of Conduct: Environmental, Social, Health and Safety (ESHS)

The Bidder shall submit the Code of Conduct that will apply to the Contract Manger and other key personnel as required by ITB 13.1 A (j) and 13.1 B (d) and **subcontractors**. The Code of Conduct shall ensure compliance with the ESHS provisions of the Contract. In addition, the Bidder shall submit an outline of how this Code of Conduct will be implemented. This will include: how it will be introduced into conditions of employment/engagement, what training will be provided, how it will be monitored and how the Contractor proposes to deal with any breaches.

Environmental, social, health and safety requirements

The Employer should use the services of a suitably qualified environmental, social, health and safety specialist/s to prepare the specifications for ESHS working with a procurement specialist/s.

The Employer should attach or refer to the Employer’s environmental, social, health and safety policies that will apply to the project. If these are not available, the Employer should use the following guidance in drafting an appropriate policy for the Works.

SUGGESTED CONTENT FOR AN ENVIRONMENTAL AND SOCIAL POLICY (STATEMENT)

The Works’ policy goal, as a minimum, should be stated to integrate environmental protection, occupational and community health and safety, gender, equality, child protection, vulnerable people (including those with disabilities), sexual harassment, gender-based violence (GBV), sexual exploitation and abuse (SEA), HIV/AIDS awareness and prevention and wide stakeholder engagement in the planning processes, programs, and activities of the parties involved in the execution of the Works. The Employer is advised to consult with the World Bank to agree the issues to be included which may also address: climate adaptation, land acquisition and resettlement, indigenous people, etc. The policy should set the frame for monitoring, continuously improving processes and activities and for reporting on the compliance with the policy.

The policy shall include a statement that, for the purpose of the policy and/or code of conduct, the term “child” / “children” means any person(s) under the age of 18 years.

The policy should, as far as possible, be brief but specific and explicit, and measurable, to enable reporting of compliance with the policy in accordance with the Particular Conditions of the Contract Sub-Clause 4.21 and Appendix C to the General Conditions of Contract.

As a minimum, the policy is set out to the commitments to:

- 1. apply good international industry practice to protect and conserve the natural environment and to minimize unavoidable impacts;*
- 2. provide and maintain a healthy and safe work environment and safe systems of work;*
- 3. protect the health and safety of local communities and users, with particular concern for those who are disabled, elderly, or otherwise vulnerable;*
- 4. ensure that terms of employment and working conditions of all workers engaged in the Works meet the requirements of the ILO labour conventions to which the host country is a signatory;*
- 5. be intolerant of, and enforce disciplinary measures for illegal activities. To be intolerant of, and enforce disciplinary measures for GBV, inhumane treatment, sexual activity with children, and sexual harassment;*
- 6. incorporate a gender perspective and provide an enabling environment where women and men have equal opportunity to participate in, and benefit from, planning and development of the Works;*
- 7. work co-operatively, including with end users of the Works, relevant authorities, contractors and local communities;*
- 8. engage with and listen to affected persons and organizations and be responsive to their concerns, with special regard for vulnerable, disabled, and elderly people;*
- 9. provide an environment that fosters the exchange of information, views, and ideas that is free of any fear of retaliation, and protects whistleblowers;*
- 10. minimize the risk of HIV transmission and to mitigate the effects of HIV/AIDS associated with the execution of the Works;*

The policy should be signed by the senior manager of the Employer. This is to signal the intent that it will be applied rigorously.

MINIMUM CONTENT OF ESHS REQUIREMENTS

In preparing detailed specifications for ESHS requirements, the specialists should refer to and consider:

- project reports e.g. ESIA/ESMP*
- consent/permit conditions*
- required standards including World Bank Group EHS Guidelines*
- relevant international conventions or treaties etc., national legal and/or regulatory requirements and standards (where these represent higher standards than the WBG EHS Guidelines)*
- relevant international standards e.g. WHO Guidelines for Safe Use of Pesticides*
- relevant sector standards e.g. EU Council Directive 91/271/EEC Concerning Urban Waste Water Treatment*

- *Grievance redress mechanism including types of grievances to be recorded and how to protect confidentiality e.g. of those reporting allegations of GBV/SEA.*
- *GBV/SEA prevention and management.*
- *The detail specification for ESHS should, to the extent possible, describe the intended outcome rather than the method of working*

The ESHS requirements should be prepared in manner that does not conflict with the relevant General Conditions of Contract and Particular Conditions of Contract, and in particular:

General Conditions of Contract

Sub-clause 1.13 Compliance with Laws

Sub-clause 2.2 Permits, Licenses and Approvals

Sub-clause 4.1 Contractor's General Obligations

Sub-clause 4.4 Subcontractors

Sub-clause 4.8 Safety Procedures

Sub-clause 4.14 Avoidance of Interference

Sub-clause 4.18 Protection of the Environment

Sub-clause 4.23 Contractor's Operations on the Site

Sub-clause 4.24 Fossils

Section 6 Staff and Labour (includes health and safety)

Sub-clause 7.1 Manner of Execution

Sub-clause 11.11 Clearance of Site

Sub-clause 12.3 Evaluation (reference ITB 14.2 "Items against which no rate or price is entered by the Bidder shall be deemed to be covered by the rates for other items in the Bill of Quantities and will not be paid separately by the Employer.")

MINIMUM REQUIREMENTS FOR THE BIDDER'S CODE OF CONDUCT

[A minimum requirement for the Code of Conduct should be set out by the Employer, taking into consideration the issues, impacts, and mitigation measures identified, for example, in:

- *project reports e.g. ESIA/ESMP*
 - *any particular GBV/SEA requirements*
 - *consent/permit conditions (regulatory authority conditions attached to any permits or approvals for the project)*
 - *required standards including World Bank Group EHS Guidelines*
 - *relevant international conventions, standards or treaties, etc., national legal and/or regulatory requirements and standards (where these represent higher standards than the WBG EHS Guidelines)*
 - *relevant standards e.g. Workers' Accommodation: Process and Standards (IFC and EBRD)*
-

- *relevant sector standards e.g. workers' accommodation*
- *Grievance redress mechanisms.*

The types of issues identified could include. Risks associated with: labor influx, spread of communicable diseases, sexual harassment, gender based violence, illicit behavior and crime, and maintaining a safe environment etc.

[Amend the following instructions to the Bidder taking into account the above considerations.]

A satisfactory code of conduct will contain obligations on all Contractor's Personnel project staff (including sub-contractors and day workers) that are suitable to address the following issues, as a minimum. Additional obligations may be added to respond to particular concerns of the region, the location and the project sector or to specific project requirements. The code of conduct shall contain a statement that the term "child" / "children" means any person(s) under the age of 18 years.

The issues to be addressed include:

1. Compliance with applicable laws, rules, and regulations
2. Compliance with applicable health and safety requirements to protect the local community (including vulnerable and disadvantaged groups), the Employer's Personnel, and the Contractor's Personnel (including wearing prescribed personal protective equipment, preventing avoidable accidents and a duty to report conditions or practices that pose a safety hazard or threaten the environment)
3. The use of illegal substances
4. Non-Discrimination in dealing with the local community (including vulnerable and disadvantaged groups), the Employer's Personnel, and the Contractor's Personnel (for example on the basis of family status, ethnicity, race, gender, religion, language, marital status, age, disability (physical and mental), sexual orientation, gender identity, political conviction or social, civic, or health status)
5. Interactions with the local community(ies), members of the local community (ies), and any affected person(s) (for example to convey an attitude of respect, including to their culture and traditions)
6. Sexual harassment (for example to prohibit use of language or behavior, in particular towards women and/or children, that is inappropriate, harassing, abusive, sexually provocative, demeaning or culturally inappropriate)
7. Violence, including sexual and/or gender based violence (for example acts that inflict physical, mental or sexual harm or suffering, threats of such acts, coercion, and deprivation of liberty)
8. Exploitation including sexual exploitation and abuse (for example the prohibition of the exchange of money, employment, goods, or services for sex, including sexual favors or other forms of humiliating, degrading behavior, exploitative behavior or abuse of power)
9. Protection of children (including prohibitions against sexual activity or abuse, or otherwise unacceptable behavior towards children, limiting interactions with children, and ensuring their safety in project areas)
10. Sanitation requirements (for example, to ensure workers use specified sanitary facilities provided by their employer and not open areas)

11. Avoidance of conflicts of interest (such that benefits, contracts, or employment, or any sort of preferential treatment or favors, are not provided to any person with whom there is a financial, family, or personal connection)
12. Respecting reasonable work instructions (including regarding environmental and social norms)
13. Protection and proper use of property (for example, to prohibit theft, carelessness or waste)
14. Duty to report violations of this Code
15. Non retaliation against workers who report violations of the Code, if that report is made in good faith.

The Code of Conduct should be written in plain language and signed by each worker to indicate that they have:

- received a copy of the code;
- had the code explained to them;
- acknowledged that adherence to this Code of Conduct is a condition of employment; and
- Understood that violations of the Code can result in serious consequences, up to and including dismissal, or referral to legal authorities.

A copy of the code shall be displayed in a location easily accessible to the community and project affected people. It shall be provided in languages comprehensible to the local community, Contractor's Personnel, Employer's Personnel, and affected persons.

PAYMENT FOR ESHS REQUIREMENTS

The Employer's ESHS and procurement specialists should consider how the Contractor will cost the delivery of the ESHS requirements. In the majority of cases, the payment for the delivery of ESHS requirements shall be a subsidiary obligation of the Contractor covered under the prices quoted for other Bill of Quantity items. For example, normally the cost of implementing work place safe systems of work, including the majors necessary for ensuring traffic safety, shall be covered by the Bidder's rates for the relevant works. Alternatively, provisional sums could be set aside for discrete activities for example for HIV counselling service, and, GBV/SEA awareness and sensitization or to encourage the contractor to deliver additional ESHS outcomes beyond the requirement of the Contract.

Section - 10

Drawings

S. N O.	DESCRIPTION	DRAWING NO	NO OF SHEETS
01.	Anicut	DIE/SINA/SAG/FDR/IWWRMP/2026/1	01

Reference Only

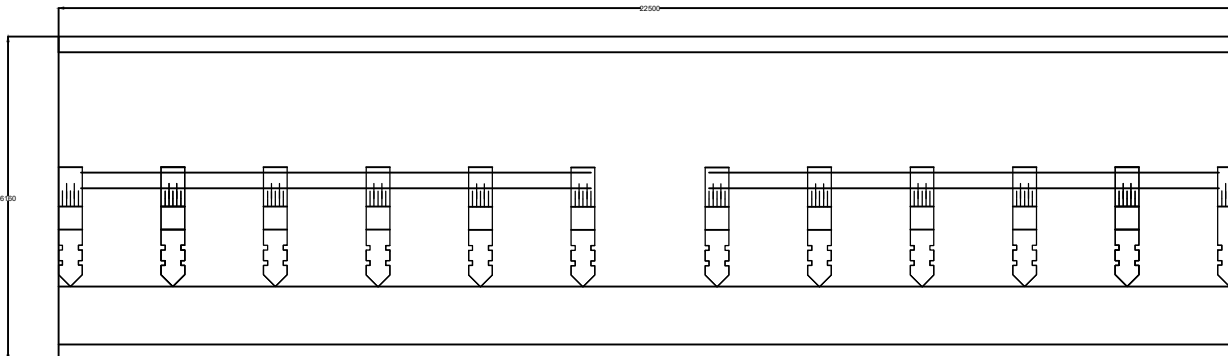
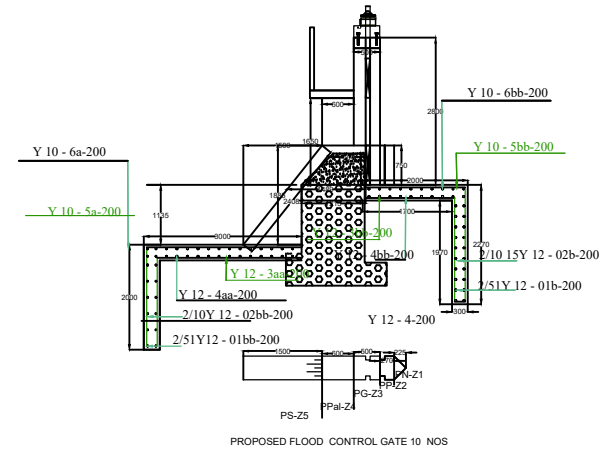
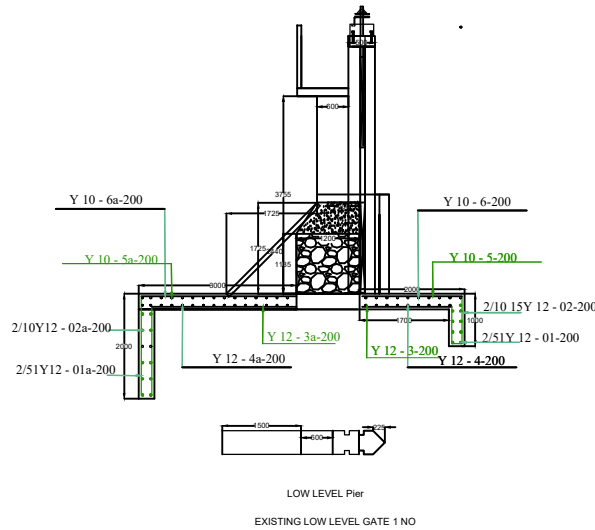
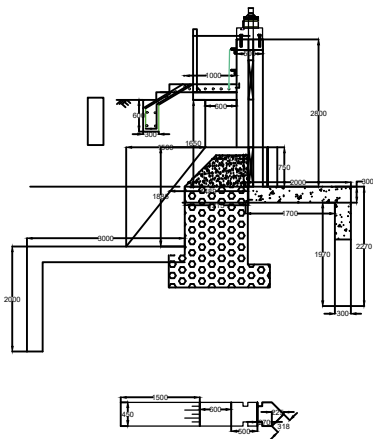
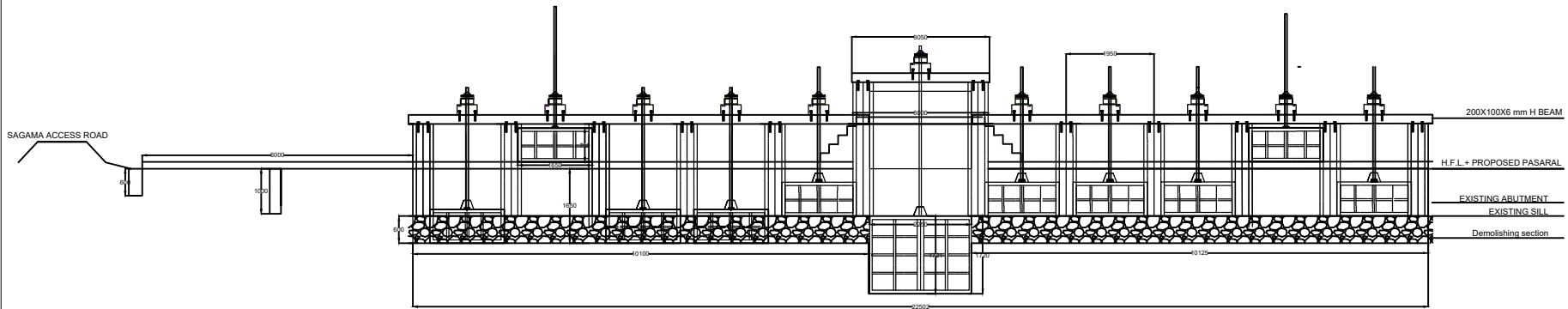

DDI's Office	LEVELLED & DRAWN BY: MR. K. G. SETHAN TECHNICAL OFFICER	DESIGNED BY: ENG. A. RAJESKANNA, DIVISIONAL IRRIGATION ENGINEER	SUBMITTED BY: ENG. A. RAJESKANNA, DIVISIONAL IRRIGATION ENGINEER
	DRAWING CHECKED BY: MRS. K. SATHIESHWANTHAN DRAUGHT PERSON	DESIGN CHECKED BY: MRS. T. RAMANEESWARAN, IRRIGATION ENGINEER	RECOMMENDED BY: ENG. G. SUJITHARAN, DEPUTY DIRECTOR OF IRRIGATION
PDI's Office	DRAWING CHECKED BY: DRAUGHT PERSON	DESIGN CHECKED BY: CHIEF IRRIGATION ENGINEER	RECOMMENDED BY: ENG. V. RAJAGOPALASINGAM, DIRECTOR OF IRRIGATION
	DESIGN RE CHECKED BY: P/ DEPUTY DIRECTOR OF IRRIGATION	DESIGN CHECKED BY: CHIEF IRRIGATION ENGINEER	RECOMMENDED BY: ENG. V. RAJAGOPALASINGAM, DIRECTOR OF IRRIGATION
PROVINCIAL IRRIGATION DEPARTMENT EASTERN PROVINCE			
REPAIR OF FLOOD DAMAGES CAUSED BY "DITWAH" CYCLONE IN 2025 BY IMPROVEMENTS TO SINNANAI ANICUT WITH GATE ARRANGEMENTS TO THAMBILUVIL DIVISION, AMPARA DISTRICT, UNDER CONTINGENT EMERGENCY RESPONSE COMPONENT (CERC)-IWWRRMP-2026			
DATE - 06.01.2026	SHEET NO- 01 OF	DRW. NO - DIE/SINA/SAG/FDR/IWWRRMP/2026/1	

Section - 11

STANDARD FORMS (BID)

Reference Only

FORM OF BID SECURITY

[this Guarantee form shall be filled in accordance with the instructions indicated in brackets]

----- [insert issuing agency's name, and address of issuing branch or office]

Beneficiary: *Project Director
Integrated Watershed & Water resources Management Project,
2nd Floor, Mahaweli Centre Building,
No. 96, Ananda Coomaraswamy Mawatha
Colombo 07.*

Date: ----- [insert (by issuing agency) date]

BID GUARANTEE No.: ----- [insert (by issuing agency) number]

We have been informed that ----- [insert (by issuing agency) name of the Bidder] (hereinafter called "the Bidder") has submitted to you its bid dated ----- [insert (by issuing agency) date] (hereinafter called "the Bid") for the execution of 'Improvements to Sinnanai Anicut with gate arrangements in Ampara District under Invitation for Bids No. LK-MOMDE-539131-CW-RFB. Furthermore, we understand that, according to your conditions, Bids must be supported by a Bid Guarantee.

At the request of the Bidder, we ----- [insert name of issuing agency] hereby irrevocably undertake to pay you any sum or sums not exceeding in total an amount of ----- [insert amount in figures] ----- [insert amount in words] upon receipt by us of your first demand in writing accompanied by a written statement stating that the Bidder is in breach of its obligation(s) under the bid conditions, because the Bidder:

- (a) has withdrawn its Bid during the period of bid validity specified; or
- (b) does not accept the correction of errors in accordance with the Instructions to Bidders (hereinafter "the ITB") of the IFB; or
- (c) having been notified of the acceptance of its Bid by the Employer/Purchaser during the period of bid validity, (i) fails or refuses to execute the Contract Form, if required, or (ii) fails or refuses to furnish the Performance Security, in accordance with the ITB.

This Guarantee shall expire: (a) if the Bidder is the successful bidder, upon our receipt of copies of the Contract signed by the Bidder and of the Performance Security issued to you by the Bidder; or (b) if the Bidder is not the successful bidder, upon the earlier of (i) the successful bidder furnishing the performance security, otherwise it will remain in force up to ----- (insert date)

Consequently, any demand for payment under this Guarantee must be received by us at the office on or before that date -----